

Fehr

**Rigging & Door
Hardware**



Fehr



Basil H.F. Fehr C.B.E.

Starting in 1857 with Henry Fehr's vision of International Trade, the Fehr family has built a solid 165 year history of doing business with honesty and integrity. Now, with fourth generation members of the Fehr family still providing that vision, we continue to build a world-wide reputation for bringing quality, integrity, and value to the markets we serve.

With our experienced staff focused on understanding these markets, buyers who exhibit a constant vigilance demanding quality products, and a culture that encourages our employees to build on our reputation, you can count on Fehr to offer quality products at competitive pricing with excellent service in an increasingly demanding marketplace.

In today's market, where the ability to research your options is as easy as it has ever been, why not turn to a Company that delivers on its promises? Fehr's depth of experience is evident each time you contact us. We're certain you'll feel that "Our Knowledge is Your Strength".

So whether you are trying us for the first time or have a long history with us, our pledge to you remains the same. We will provide you with the quality you need, the pricing to keep you competitive, and with a service level of shipping your order complete, correct, and on time each and every time.

RIGGING HARDWARE

CABLE & WIRE ROPE	5-25
Cable	5
Wire Rope	11
Wire Rope Fitting	15
Guy Strand	17
Cable Assemblies & Fitting	19
Steel Slings	24
Cable Adjusters	25
CHAIN	26-34
Welded	27
Stainless Steel	28
Utility	30
Binders	32
Alloy Lifting Products	33
Pump Lifting Products	34
TOOLS	35-42
Chain & Bolt Cutters	35
Wire Cutters	36
Swagers	36
Swaging Tools & Kits	37
Grips	39
Cable Pullers	40
Measuring Tools	40
Cutter Accessories	41
Garage Door Tools	41
POLYESTER SLINGS	43-45
Tuflex® Round Slings	43
Stage Slings	44
Tuff-Edge® III Flat Web Slings	45
BLOCKS & PULLEYS	46-50
Blocks & Sheaves	46
Pulleys	47
Winches	49
ANCHORS	51
Painted	51
Galvanized	51

TURNBUCKLES	52-55
Hot Galvanized	52
Stainless Steel	55
CONNECTORS	56-61
Quick Links	56
Pear Links	56
Swivels	57
Connecting Links	58
S-Hooks	59
Snap Hooks	60
Spring Hooks	60
HOOKS	62-64
Slip	62
Grab	63
Hoist	64
SHACKLES	65-68
Screw Pin Anchor	65
Screw Pin Chain	66
Safety	67
Commercial Grade	67
Stainless Steel	68
EYEBOLTS	69-70
Hot Galvanized	69
Machinery	70
FASTENERS	71-76
Eye Lag Screws	71
J-Lag Hooks	71
Screws	72
Bolts & Nuts	73
Anchors	75
Maze Nails	76
LUBRICANT	77-80
Fehr Lubes	77
Lubriplate	78
Hand Cleaner Towels	78
Slipit	79



GARAGE DOOR HARDWARE

ROLLERS	82-84
Nylon	82
Precision Bearing	83
Steel	83
PERFORATED ANGLE	85
Painted Angle	85
Hot Galvanized	85
HINGES	86-87
Commercial & Industrial	86
Residential	86
Narrow Design	87
BRACKETS	87-90
Top Brackets	87
Operator Brackets	88
Bottom Brackets	89
Jamb	90
LOCKS	91-94
Side Locks	91
Locking Handles & Cylinders	91
Latches & Strikers	92
Locks Components	93
Key Switches & Disconnect Devices	93
Snap-Latch	93
Lock Sets	94
BEARING PLATES	94-95
End & Flat End Plates	94
Decorator Angles	94
Spring Anchor	95
Bearing	95
SHEAVES	96-97
Stamped Sheave	96
Cast Sheave	96
Sheave Forks	96
Sheaves Kits	97
Chain Hoists	97
Spreader Bar	97

CABLE	98-99
Torsion Doors Assemblies	98
Extension Doors Assemblies	99
SPRINGS	100-108
Torsion Springs	100
Extension Springs	104
Spring Restraint Cables	105
Lock Bar Spring	105
Extension & Bumper Springs	106
Spring Fittings	107
Cones & Drums	108
WEATHER SEAL	109-118
Royal Uniflex™ Thermostop	109
Wood Grain Jamb Seal	111
Rigid Door Stop	111
Rolled Solid Door Stop	112
Stucco Jamb Seal	112
Reverse Angle Seals	112
Rolling Steel	113
Top Seals	113
Mini Warehouse	113
Bottom Seals	116
Bottom Astragal Seals	116
Retainers	117
Rodent Control	118
TRUCK DOOR HARDWARE	119-121
Stainless & Galvanized Assemblies	119
Hinges	120
Brackets	120
Rollers	121
Step Bolts	121
Drums	121
CABLE RAILING HARDWARE	122
CUSTOM CABLE & CHAIN ASSEMBLIES	124
FULL INDEX	125
TERMS & CONDITIONS	128



CABLE

FEHR CABLE AND WIRE ROPE IS INDEPENDENT LAB CERTIFIED AND MEETS THE PERFORMANCE REQUIREMENTS OF APPLICABLE FEDERAL SPECIFICATION RR-W-410.



HOT DIP GALVANIZED CABLE

Size	Type	Breaking Strength (Lbs)	Part # 250' Reel	Part # 500' Reel	Part # 1,000' Reel	Part # 5,000' Reel	Wt (Lbs)/Ft
1/16"	1x7	480	2G1062-00250	2G1062-00500	2G1062-01000	2G1062-05000	0.010
3/64"	1x19	375	2G19047-00250	2G19047-00500	2G19047-01000	2G19047-05000	0.006
1/16"	1x19	500	2G19062-00250	2G19062-00500	2G19062-01000	2G19062-05000	0.008
5/64"	1x19	800	2G19078-00250	2G19078-00500	2G19078-01000	2G19078-05000	0.014
3/32"	1x19	1,200	2G19093-00250	2G19093-00500	2G19093-01000	2G19093-05000	0.020



1x19

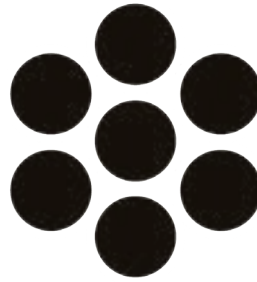

1x7

Small reels are boxed and labelled.



Large reels have sturdy wood flange.



2G19062-05000



2G1062-01000

- Standard reels: 250', 500', 1,000', 5,000'
 - Custom lengths and test certifications available. Call 800.431.3095 for details.



- Custom Cable Assemblies Available. Call for details.



HOT DIP GALVANIZED CABLE

Size	Type	Breaking Strength (Lbs)	Part # 250' Reel	Part # 500' Reel	Part # 1,000' Reel	Part # 2,500' Reel	Part # 5,000' Reel	Wt (Lbs)/Ft
3/64"	7 x 7	270	2G7047-00250	2G7047-00500	2G7047-01000	2G7047-02500	2G7047-05000	0.005
1/16"	7 x 7	480	2G7062-00250	2G7062-00500	2G7062-01000	2G7062-02500	2G7062-05000	0.008
5/64"	7 x 7	650	2G7078-00250	2G7078-00500	2G7078-01000	2G7078-02500	2G7078-05000	0.012
3/32"	7 x 7	920	2G7093-00250	2G7093-00500	2G7093-01000	2G7093-02500	2G7093-05000	0.016
1/8"	7 x 7	1,700	2G7125-00250	2G7125-00500	2G7125-01000	2G7125-02500	2G7125-05000	0.028
5/32"	7 x 7	2,600	2G7156-00250	2G7156-00500	2G7156-01000	2G7156-02500	2G7156-05000	0.046
3/16"	7 x 7	3,700	2G7187-00250	2G7187-00500	2G7187-01000	2G7187-02500	2G7187-05000	0.064
1/4"	7 x 7	6,100	2G7250-00250	2G7250-00500	2G7250-01000	2G7250-02500	2G7250-05000	0.106
3/32"	7 x 19	1,000	2G9093-00250	2G9093-00500	2G9093-01000	2G9093-02500	2G9093-05000	0.017
1/8"	7 x 19	2,000	2G9125-00250	2G9125-00500	2G9125-01000	2G9125-02500	2G9125-05000	0.029
5/32"	7 x 19	2,800	2G9156-00250	2G9156-00500	2G9156-01000	2G9156-02500	2G9156-05000	0.045
3/16"	7 x 19	4,200	2G9187-00250	2G9187-00500	2G9187-01000	2G9187-02500	2G9187-05000	0.065
7/32"	7 x 19	5,600	2G9218-00250	2G9218-00500	2G9218-01000	2G9218-02500	2G9218-05000	0.089
1/4"	7 x 19	7,000	2G9250-00250	2G9250-00500	2G9250-01000	2G9250-02500	2G9250-05000	0.111
5/16"	7 x 19	9,800	2G9312-00250	2G9312-00500	2G9312-01000	2G9312-02500	2G9312-05000	0.173
3/8"	7 x 19	14,400	2G9375-00250	2G9375-00500	2G9375-01000	2G9375-02500	2G9375-05000	0.243



7 x 7 - FLEXIBLE



7 x 19 - EXTRA FLEXIBLE

Small reels are boxed and labelled.



Large reels have sturdy wood flange.



- Standard reels: 250', 500', 1,000', 2,500', 5,000'
 - Custom lengths and test certifications available. Call 800.431.3095 for details.



VINYL COATED HOT DIP GALVANIZED CABLE



Size	Type	Breaking Strength (Lbs)	Part # 250' Reel	Part # 500' Reel	Part # 1,000' Reel	Part # 5,000' Reel	Color	Wt (Lbs)/ Ft
1/16" - 3/32"	7 x 7	480	2V7062-093-00250	2V7062-093-00500	2V7062-093-01000	2V7062-093-05000	Clear	0.012
3/32" - 3/16"	7 x 7	920	2V7093-187-00250	2V7093-187-00500	2V7093-187-01000	2V7093-187-05000	Clear	0.028
1/8" - 3/16"	7 x 7	1,700	2V7125-187-00250	2V7125-187-00500	2V7125-187-01000	2V7125-187-05000	Clear	0.044
1/8" - 3/16"	7 x 7	1,700	2VB7125-187-00250	2VB7125-187-00500	2VB7125-187-01000	2VB7125-187-05000	Black	0.044
1/8" - 3/16"	7 x 7	1,700	2VR7125-187-00250	2VR7125-187-00500	2VR7125-187-01000	2VR7125-187-05000	Red	0.044
1/8" - 3/16"	7 x 19	2,000	2VR9125-187-00250	2VR9125-187-00500	2VR9125-187-01000	2VR9125-187-05000	Red	0.046
3/16" - 1/4"	7 x 19	4,200	2V9187-250-00250	2V9187-250-00500	2V9187-250-01000	2V9187-250-05000	Clear	0.088
1/4" - 5/16"	7 x 19	7,000	2V9250-312-00250	2V9250-312-00500	2V9250-312-01000	2V9250-312-05000	Clear	0.135
5/16" - 3/8"	7 x 19	9,800	2V9312-375-00250	2V9312-375-00500	2V9312-375-01000	2V9312-375-05000	Clear	0.224

- Additional colors available by special order. Call 800.431.3095 for details.



NYLON COATED HOT DIP GALVANIZED CABLE



Size	Type	Breaking Strength (Lbs)	Part # 250' Reel	Part # 500' Reel	Part # 1,000' Reel	Part # 5,000' Reel	Color	Wt (Lbs)/ Ft
1/16" - 3/32"	7 x 7	480	2N7062-093-00250	2N7062-093-00500	2N7062-093-01000	2N7062-093-05000	Clear	0.012
1/8" - 3/16"	7 x 19	2,000	2N9125-187-00250	2N9125-187-00500	2N9125-187-01000	2N9125-187-05000	Clear	0.044
1/8" - 3/16"	7 x 19	2,000	2NB125-187-00250	2NB125-187-00500	2NB125-187-01000	2NB125-187-05000	Black	0.044
3/16" - 1/4"	7 x 19	4,200	2N9187-250-00250	2N9187-250-00500	2N9187-250-01000	2N9187-250-05000	Clear	0.079
3/16" - 1/4"	7 x 19	4,200	2NB187-250-00250	2NB187-250-00500	2NB187-250-01000	2NB187-250-05000	Black	0.079
1/4" - 5/16"	7 x 19	7,000	2NB9250-312-00250	2NB9250-312-00500	2NB9250-312-01000	2NB9250-312-05000	Black	0.120

- Additional colors available by special order. Call 800.431.3095 for details.



Black coating masks cable from sight in lighting, sound and scenery applications.



BLACK COATED HOT DIP GALVANIZED CABLE

Size	Type	Breaking Strength (Lbs)	Part # 250' Reel	Part # 500' Reel	Part # 1,000' Reel	Part # 5,000' Reel	Wt (Lbs)/Ft
5/32"	1 x 19	3,300	2G1B156-00250	2G1B156-00500	2G1B156-01000	2G1B156-05000	0.013
1/16"	7 x 7	480	2G7B062-00250	2G7B062-00500	2G7B062-01000	2G7B062-05000	0.008
3/32"	7 x 19	1,500	2G9B093-00250	2G9B093-00500	2G9B093-01000	2G9B093-05000	0.018
1/8"	7 x 19	2,000	2G9B125-00250	2G9B125-00500	2G9B125-01000	2G9B125-05000	0.029
3/16"	7 x 19	4,200	2G9B187-00250	2G9B187-00500	2G9B187-01000	2G9B187-05000	0.065
1/4"	7 x 19	7,000	2G9B250-00250	2G9B250-00500	2G9B250-01000	2G9B250-05000	0.111
5/16"	7 x 19	9,800	2G9B312-00250	2G9B312-00500	2G9B312-01000	2G9B312-05000	0.175
3/8"	7 x 19	14,400	2G9B375-00250	2G9B375-00500	2G9B375-01000	2G9B375-05000	0.243



STAINLESS STEEL CABLE - TYPE 304

Size	Type	Breaking Strength (Lbs)	Part # 250' Reel	Part # 500' Reel	Part # 1,000' Reel	Part # 5,000' Reel	Wt (Lbs)/Ft
1/16"	1 x 7	480	2S1062-00250	2S1062-00500	2S1062-01000	2S1062-05000	0.010
3/64"	7 x 7	270	2S7047-00250	2S7047-00500	2S7047-01000	2S7047-05000	0.004
1/16"	7 x 7	480	2S7062-00250	2S7062-00500	2S7062-01000	2S7062-05000	0.008
3/32"	7 x 7	920	2S7093-00250	2S7093-00500	2S7093-01000	2S7093-05000	0.016
1/8"	7 x 7	1,700	2S7125-00250	2S7125-00500	2S7125-01000	2S7125-05000	0.028
3/16"	7 x 7	3,700	2S7187-00250	2S7187-00500	2S7187-01000	2S7187-05000	0.063
3/32"	7 x 19	920	2S9093-00250	2S9093-00500	2S9093-01000	2S9093-05000	0.017
1/8"	7 x 19	1,760	2S9125-00250	2S9125-00500	2S9125-01000	2S9125-05000	0.029
5/32"	7 x 19	2,400	2S9156-00250	2S9156-00500	2S9156-01000	2S9156-05000	0.045
3/16"	7 x 19	3,700	2S9187-00250	2S9187-00500	2S9187-01000	2S9187-05000	0.065
1/4"	7 x 19	6,400	2S9250-00250	2S9250-00500	2S9250-01000	2S9250-05000	0.110
5/16"	7 x 19	9,000	2S9312-00250	2S9312-00500	2S9312-01000	2S9312-05000	0.173
3/8"	7 x 19	12,000	2S9375-00250	2S9375-00500	2S9375-01000	2S9375-05000	0.243



Versatile and widely used. Provides good resistance to moderately acidic or caustic environments.



1 x 7



7 x 7 - FLEXIBLE



7 x 19 - EXTRA FLEXIBLE



STAINLESS STEEL CABLE - TYPE 316

Size	Type	Breaking Strength (Lbs)	Part # 250' Reel	Part # 500' Reel	Part # 1,000' Reel	Part # 5,000' Reel	Wt (Lbs)/Ft
1/8"	1 x 19	1,780	2T19125-00250	2T19125-00500	2T19125-01000	2T19125-05000	0.040
5/32"	1 x 19	2,800	2T19156-00250	2T19156-00500	2T19156-01000	2T19156-05000	0.060
3/16"	1 x 19	4,000	2T19187-00250	2T19187-00500	2T19187-01000	2T19187-05000	0.077
1/16"	7 x 7	420	2T7062-00250	2T7062-00500	2T7062-01000	2T7062-05000	0.008
1/8"	7 x 19	1,530	2T9125-00250	2T9125-00500	2T9125-01000	2T9125-05000	0.029
3/16"	7 x 19	2,900	2T9187-00250	2T9187-00500	2T9187-01000	2T9187-05000	0.065
1/4"	7 x 19	4,900	2T9250-00250	2T9250-00500	2T9250-01000	2T9250-05000	0.110
5/16"	7 x 19	7,600	2T9312-00250	2T9312-00500	2T9312-01000	2T9312-05000	0.173
3/8"	7 x 19	11,000	2T9375-00250	2T9375-00500	2T9375-01000	2T9375-05000	0.243

- Standard reels in 7x7 and 7x19: 250', 500', 1,000', 5,000'.
 - Custom lengths and test certificates available. Call 800.431.3095 for details.



Chris



T316

Superior resistance to corrosion and oxidation. Recommended for use in marine and salt water environments.



HOT DIP GALVANIZED STEEL CABLE - LEFT HAND LAY

Size	Type	Breaking Strength (Lbs)	Part # 250' Reel	Part # 500' Reel	Part # 1,000' Reel	Part # 5,000' Reel	Wt (Lbs)/Ft
1/8"	7 x 19	2,000	2G9125LH-00250	2G9125LH-00500	2G9125LH-01000	2G9125LH-05000	0.029
5/32"	7 x 19	2,800	2G9156LH-00250	2G9156LH-00500	2G9156LH-01000	2G9156LH-05000	0.045

- Standard reels: 250', 500', 1,000', 5,000'
- Custom lengths and test certificates available. Call 800.431.3095 for details.



RIGHT LAY

LEFT LAY

Left Lay Cable is stranded in the opposite direction from standard cable.



ZN-AL COATED STEEL CABLE

Size	Type	Breaking Strength (Lbs)	Part # 250' Reel	Part # 500' Reel	Part # 1,000' Reel	Part # 5,000' Reel	Wt (Lbs)/Ft
1/8"	7 x 7	1,700	2ZA7125-00250	2ZA7125-00500	2ZA7125-01000	2ZA7125-05000	0.028
3/16"	7 x 19	3,700	2ZA9187-00250	2ZA9187-00500	2ZA9187-01000	2ZA9187-05000	0.064
1/4"	7 x 19	7,000	2ZA9250-00250	2ZA9250-00500	2ZA9250-01000	2ZA9250-05000	0.111

- Standard reels in 7x7 and 7x19: 250', 500', 1,000', 5,000'
- Custom lengths and test certificates available. Call 800.431.3095 for details.



Two to three times the corrosion protection of hot dip galvanizing.

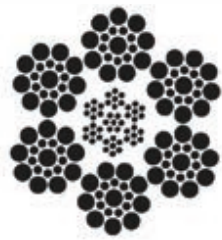

6 x 19

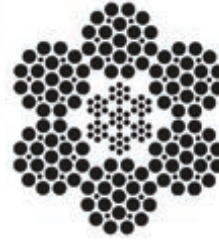

6 x 25



BRIGHT STEEL CENTER WIRE ROPE - IWRC EIPS RRL

Size	Type	Breaking Strength (Lbs)	Part # 250' Reel	Part # 500' Reel	Part # 1,000' Reel	Part # 5,000' Reel	Wt (Lbs)/Ft
1/4"	6 x 19	6,800	BW19S250-00250	BW19S250-00500	BW19S250-01000	BW19S250-05000	0.12
5/16"	6 x 19	10,540	BW19S312-00250	BW19S312-00500	BW19S312-01000	BW19S312-05000	0.18
3/8"	6 x 19	15,100	BW19S375-00250	BW19S375-00500	BW19S375-01000	BW19S375-05000	0.26
1/2"	6 x 25	26,600	BW25S500-00250	BW25S500-00500	BW25S500-01000	BW25S500-05000	0.46
5/8"	6 x 25	41,200	BW25S625-00250	BW25S625-00500	BW25S625-01000	BW25S625-05000	0.72
3/4"	6 x 25	58,800	BW25S750-00250	BW25S750-00500	BW25S750-01000	BW25S750-05000	1.04
7/8"	6 x 25	79,600	BW25S875-00250	BW25S875-00500	BW25S875-01000	BW25S875-05000	1.42
1"	6 x 25	103,400	BW25S100-00250	BW25S100-00500	BW25S100-01000	BW25S100-05000	1.85

- Additional types and dimensions available. Call 800.431.3095 for details.



BRIGHT WIRE ROPE - FC IPS RRL

Size	Type	Breaking Strength (Lbs)	Part # 250' Reel	Part # 500' Reel	Part # 1,000' Reel	Part # 5,000' Reel	Wt (Lbs)/Ft
3/16"	6 x 19	3,100	BW19F187-00250	BW19F187-00500	BW19F187-01000	BW19F187-05000	0.06
1/4"	6 x 19	5,480	BW19F250-00250	BW19F250-00500	BW19F250-01000	BW19F250-05000	0.11
5/16"	6 x 19	8,520	BW19F312-00250	BW19F312-00500	BW19F312-01000	BW19F312-05000	0.16
3/8"	6 x 19	12,200	BW19F375-00250	BW19F375-00500	BW19F375-01000	BW19F375-05000	0.24
7/16"	6 x 19	16,540	BW19F437-00250	BW19F437-00500	BW19F437-01000	BW19F437-05000	0.32
1/2"	6 x 25	21,400	BW25F500-00250	BW25F500-00500	BW25F500-01000	BW25F500-05000	0.42
5/8"	6 x 25	33,400	BW25F625-00250	BW25F625-00500	BW25F625-01000	BW25F625-05000	0.66
3/4"	6 x 25	47,600	BW25F750-00250	BW25F750-00500	BW25F750-01000	BW25F750-05000	0.95

- Additional types and dimensions available. Call 800.431.3095 for details.



6 x 19



6 x 25



HOT DIP GALVANIZED WIRE ROPE - IWRC EIPS RRL

Size	Type	Breaking Strength (Lbs)	Part # 250' Reel	Part # 500' Reel	Part # 1,000' Reel	Part # 5,000' Reel	Wt (Lbs)/Ft
1/2"	6 x 25	24,000	GW25S500-00250	GW25S500-00500	GW25S500-01000	GW25S500-05000	0.46
5/8"	6 x 25	37,000	GW25S625-00250	GW25S625-00500	GW25S625-01000	GW25S625-05000	0.72
3/4"	6 x 25	53,000	GW25S750-00250	GW25S750-00500	GW25S750-01000	GW25S750-05000	1.04



6 x 25

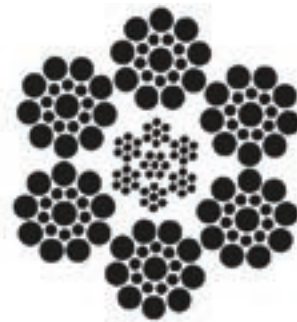

6 x 19



STAINLESS STEEL WIRE ROPE - TYPE 304, IWRC IPS RRL

Size	Type	Breaking Strength (Lbs)	Part # 250' Reel	Part # 500' Reel	Part # 1,000' Reel	Part # 5,000' Reel	Wt (Lbs)/Ft
7/16"	6 x 19	16,300	SW19S437-00250	SW19S437-00500	SW19S437-01000	SW19S437-05000	0.35
1/2"	6 x 19	22,800	SW19S500-00250	SW19S500-00500	SW19S500-01000	SW19S500-05000	0.46
5/8"	6 x 25	35,000	SW25S625-00250	SW25S625-00500	SW25S625-01000	SW25S625-05000	0.72
3/4"	6 x 25	49,600	SW25S750-00250	SW25S750-00500	SW25S750-01000	SW25S750-05000	1.04

- FC: Fiber Core Center / IWRC: Independent Wire Rope Center / IPS: Improved Plow Steel / EIPS: Extra Improved Plow Steel / RRL: Right Regular Lay

The construction of this wire rope reduces rotation under load.

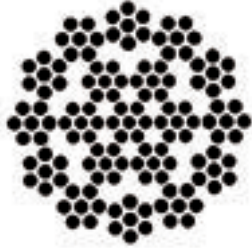

Dana



ROTATION RESISTANT BRIGHT WIRE ROPE

Size	Type	Breaking Strength (Lbs)	Part # 250' Reel	Part # 500' Reel	Part # 1,000' Reel	Part # 5,000' Reel	Wt (Lbs)/Ft
3/8"	19 x 7	11,180	BW19N375-00250	BW19N375-00500	BW19N375-01000	BW19N375-05000	0.025
1/2"	19 x 7	19,700	BW19N500-00250	BW19N500-00500	BW19N500-01000	BW19N500-05000	0.045
5/8"	19 x 7	30,600	BW19N625-00250	BW19N625-00500	BW19N625-01000	BW19N625-05000	0.072
3/4"	19 x 7	43,600	BW19N750-00250	BW19N750-00500	BW19N750-01000	BW19N750-05000	0.102



GALVANIZED DOUBLE SWAGED WIRE ROPE - IWRC EIPS RRL

Size	Type	Breaking Strength (Lbs)	Part # 250' Reel	Part # 500' Reel	Part # 1,000' Reel	Part # 5,000' Reel	Wt (Lbs)/Ft
3/8"	6 x 26	20,400	GSDW26S375-00250	GSDW26S375-00500	GSDW26S375-01000	GSDW26S375-05000	0.034
1/2"	6 x 26	34,000	GSDW26S500-00250	GSDW26S500-00500	GSDW26S500-01000	GSDW26S500-05000	0.062
5/8"	6 x 26	54,000	GSDW26S625-00250	GSDW26S625-00500	GSDW26S625-01000	GSDW26S625-05000	0.096

- IWRC: Independent Wire Rope Center, EIPS: Extra Improved Plow Steel, RRL: Right Regular Lay

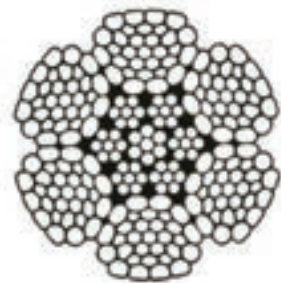

FEHR GALVANIZED WIRE ROPE CLIPS MEET THE PERFORMANCE REQUIREMENTS OF APPLICABLE FEDERAL SPECIFICATION FF-C-450.



WIRE ROPE CLIPS - MALLEABLE ELECTROGALVANIZED

Part #	Cable Size	Minimum Clips Required	Dealer Pack	Bulk	Wt (Lbs)/ 100 Pcs
WRCG062	1/16"	3	100	1,500	2.20
WRCG125	1/8"	3	100	1,250	3.60
WRCG187	3/16"	3	100	750	6.40
WRCG250	1/4"	3	100	400	12.00
WRCG312	5/16"	3	100	300	14.00
WRCG375	3/8"	3	100	250	22.00
WRCG437	7/16"	4	100	--	24.00
WRCG500	1/2"	4	100	--	38.00
WRCG625	5/8"	4	50	100	60.00
WRCG750	3/4"	5	25	50	80.00
WRCG875	7/8"	5	25	50	128.00
WRCG100	1"	6	25	50	148.00



WRCG625

Ideal for fencing, hand rails, animal runs, and other applications that do not sustain overhead loads.



WIRE ROPE CLIPS - DROP FORGED GALVANIZED

Part #	Cable Size	Minimum Clips Required	Dealer Pack	Bulk	Wt (Lbs)/ 100 Pcs
WRCDF125	1/8"	2	10	500	6
WRCDF125-USA	1/8"	2	1	--	6
WRCDF187	3/16"	2	10	500	10
WRCDF187-USA	3/16"	2	1	--	10
WRCDF250	1/4"	2	10	300	20
WRCDF250-USA	1/4"	2	1	--	20
WRCDF312	5/16"	2	10	200	30
WRCDF375	3/8"	2	10	125	50
WRCDF437	7/16"	2	10	80	70
WRCDF500	1/2"	3	10	80	75
WRCDF625	5/8"	3	10	50	100
WRCDF750	3/4"	4	10	50	150
WRCDF875	7/8"	4	10	25	220
WRCDF100	1"	5	10	25	250



WRCDF500



How to use Wire Rope Clips

- Drop forged wire rope clips should be used in applications where strength is paramount.



DOUBLE SADDLE GRIP WIRE ROPE CLIPS - DROP FORGED GALVANIZED

Part #	Cable Size	Minimum Clips Required	Wt (Lbs)/Ea
FG250	1/4"	2	0.25
FG312	5/16"	2	0.27
FG375	3/8"	2	0.27
FG500	1/2"	3	0.55



Double saddle clips are galvanized to resist corrosion, design allows for quick installation and disassembly.



STAINLESS STEEL WIRE ROPE CLIPS - TYPE 304 PRECISION CAST

Part #	Trade Size	Cable Size	Minimum Clips Required	Wt (Lbs)/Ea
SWRC062	2 mm	1/16"	3	0.02
SWRC093	3 mm	3/32"	3	0.03
SWRC125	4 mm	1/8"	3	0.04
SWRC187	5 mm	3/16"	3	0.08
SWRC250	6 mm	1/4"	3	0.09
SWRC312	8 mm	5/16"	3	0.18
SWRC375	10 mm	3/8"	3	0.34
SWRC500	12 mm	1/2"	4	0.51
SWRC625	16 mm	5/8"	4	0.87
SWRC750	19 mm	3/4"	5	1.06



Type 304 stainless steel wire rope clips offer the corrosion resistance and durability needed in high moisture environments.



STAINLESS STEEL WIRE ROPE CLIPS - TYPE 316 PRECISION CAST

Part #	Cable Size	Minimum Clips Required	Wt (Lbs)/Ea
SWRC125-T316	1/8"	3	0.06
SWRC187-T316	3/16"	3	0.10
SWRC250-T316	1/4"	3	0.18
SWRC312-T316	5/16"	3	0.27
SWRC375-T316	3/8"	3	0.45
SWRC500-T316	1/2"	4	0.71
SWRC625-T316	5/8"	4	1.00



Type 316 stainless steel wire rope clips offer higher corrosion resistance in salt, chloride and acidic conditions.

FEHR GUY STRAND MEETS ASTM A-475 SPECIFICATION AND IS CLASS A GALVANIZED.



GUY STRAND - EHS (EXTRA HIGH STRENGTH)

Part #	Diameter	Type	Breaking Strength (Lbs)	Coil Size (Ft)	Wt (Lbs)/Ft
2G1E187	3/16"	1 x 7	3,990	250	0.07
2G1E250	1/4"	1 x 7	6,650	250	0.12
2G1E312	5/16"	1 x 7	11,200	200	0.21
2G1E375	3/8"	1 x 7	15,400	150	0.25
2G1E437	7/16"	1 x 7	20,800	--	0.40
2G1E500	1/2"	1 x 7	26,900	--	0.52



2G1E187



- Guy Strand is 7 strand, left hand lay.
- Coils installed in a safety dispenser. Reels available in 500', 1,000', 5,000' and custom lengths. Call 800.431.3095 for details.



GUY STRAND - COMMON GRADE

Part #	Diameter	Type	Breaking Strength (Lbs)	Coil Size (Ft)	Wt (Lbs)/Ft
2G1C125-00250	1/8"	1 x 7	540	250	0.03
2G1C187-00250	3/16"	1 x 7	1,150	250	0.07
2G1C250-00250	1/4"	1 x 7	1,900	250	0.12
2G1C312-00250	5/16"	1 x 7	3,200	250	0.20



2G1C125-00250



- Guy Strand is 7 strand, left hand lay.



GUY STRAND SPLICES

Part #	Strand Size	Wt (Lbs)/Ea
GSS187	3/16"	0.40
GSS250	1/4"	0.51
GSS312	5/16"	0.80
GSS375	3/8"	1.20



GSS312

GSS187

Splice two pieces of like strand.



Terminate overhead or down guy wire, universal bale design.



GST312



GUY STRAND TENSIONERS

Part #	Strand Size	Wt (Lbs)/Ea
GST187	3/16"	0.45
GST250	1/4"	0.56
GST312	5/16"	1.20
GST375	3/8"	1.53

NOTE: Guy Strand Splices and Tensioners are rated to hold a minimum of 90% RBS (Rated Breaking Strength) for strand use. For use with 1 x 7 EHS Guy Strand only.



PLP PREFORMED LINE PRODUCTS
The connection you can count on. **MADE IN USA**

GALVANIZED PLP TREE-GRIP™ DEAD-ENDS

Part #	Strand Size	Breaking Strength (Lbs)	Color	Pcs/Carton	Wt (Lbs)/Ea
TG187-PLP	3/16"	3,990	Red	100	0.15
TG250-PLP	1/4"	6,650	Yellow	100	0.25
TG312-PLP	5/16"	11,200	Black	50	0.55
TG375-PLP	3/8"	15,400	Orange	50	0.90



TG187-PLP



GALVANIZED PLP BIG-GRIP DEAD-ENDS

Part #	Strand Size	Breaking Strength (Lbs)	Color	Pcs/Carton	Wt (Lbs)/Ea
BG250	1/4"	6,650	Yellow	50	0.54
BG312	5/16"	11,200	Black	50	0.86
BG375	3/8"	15,400	Orange	25	1.40
BG437	7/16"	20,800	Green	25	1.88
BG500	1/2"	26,900	Blue	20	3.15



WG-1250



PLP END SLEEVES

Part #	Strand Size	Wt (Lbs)/Ea
ES250	1/4"	0.06
ES312	5/16"	0.06
ES375	3/8"	0.06
ES437	7/16"	0.07
ES500	1/2"	0.08



PLP WEDGE GRIP ASSEMBLY

Part #	Strand Size	EHS RBS (Lbs)	Wt (Lbs)/Ea
WG-1250	3/16"	3,990	0.06
WG-1251	1/4"	6,650	0.06
WG-1252	5/16"	11,200	0.06
WG-1253	3/8"	15,400	0.07



Lighting Restraint Cables can be attached to fixtures to guard against them falling when the primary method of attachment fails. These steel cable assemblies are secured around a pipe or truss of a stage lighting fixture then clipped on itself using the attached spring clip. Safety cables are mandatory in most stage rigging applications as they afford an extra measure of security and protection from possible support structure failure.



LIGHTING RESTRAINT CABLES

Part #	Finish	Snap Size	Length
39250-30	Galvanized	1/4"	30"
39312-18	Galvanized	5/16"	18"
39312-18B	Black	5/16"	18"
39312-30	Galvanized	5/16"	30"
39312-30B	Black	5/16"	30"
39312-30S	Stainless Steel	5/16"	30"
39312-30W	White	5/16"	30"

- Custom assemblies available by special order. Call 800.431.3095 for details.

Lighting Restraint Cables are constructed of 1/8" 7x7 Cable, No. 2450 Spring Hooks at one end and plain loops at the other.



39312-30W



Can be attached to fixtures to keep them from falling when primary method of attachment fails.



39312-30



39312-30B

When properly crimped, will hold the rated breaking strength of the cable.

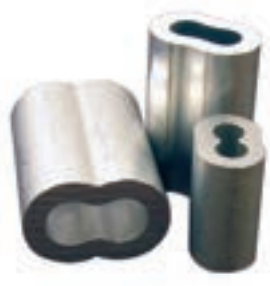

ASL062



ALUMINUM SLEEVES

Part #	Cable Size	Dealer Pack	Bulk	Wt (Lbs)/ 100 Pcs
ASL062	1/16"	100	1,000	0.08
ASL078	5/64"	100	1,000	0.16
ASL093	3/32"	100	1,000	0.33
ASL125	1/8"	100	1,000	0.63
ASL156	5/32"	100	1,000	0.84
ASL187	3/16"	100	1,000	1.55
ASL250	1/4"	100	1,000	2.53
ASL312	5/16"	100	1,000	4.60
ASL375	3/8"	100	1,000	5.92
ASL500	1/2"	1	--	18.00



Copper sleeves work with galvanized and stainless steel cable.



CSL093



COPPER SLEEVES

Part #	Cable Size	Dealer Pack	Bulk	Wt (Lbs)/ 100 Pcs
CSL047	3/64"	100	1,000	0.17
CSL062	1/16"	100	1,000	0.26
CSL093	3/32"	100	1,000	0.62
CSL125	1/8"	100	1,000	1.65
CSL156	5/32"	100	--	2.26
CSL187	3/16"	100	1,000	5.31
CSL250	1/4"	100	--	7.65
CSL312	5/16"	100	--	12.46
CSL375	3/8"	100	--	15.87
CSL500	1/2"	1	--	40.00



COPPER SLEEVES - ZINC PLATED

Part #	Cable Size	Dealer Pack	Bulk	Wt (Lbs)/ 100 Pcs
ZPCSL062	1/16"	100	1,000	0.30
ZPCSL093	3/32"	100	1,000	0.75
ZPCSL125	1/8"	100	1,000	1.72
ZPCSL187	3/16"	100	1,000	5.22
ZPCSL250	1/4"	100	--	8.00
ZPCSL312	5/16"	1	--	14.00
ZPCSL375	3/8"	1	--	17.60
ZPCSL500	1/2"	1	--	39.00

Works well with stainless steel cable.



ZPCSL250



STAINLESS STEEL SLEEVES - TYPE 316

Part #	Cable Size	Wt (Lbs)/ 100 Pcs
SSL062-T316	1/16"	0.25
SSL093-T316	3/32"	0.27
SSL125-T316	1/8"	0.64
SSL187-T316	3/16"	2.50
SSL250-T316	1/4"	4.25
SSL312-T316	5/16"	6.00



ALUMINUM STOPS

Part #	Cable Size	Dealer Pack	Bulk	Wt (Lbs)/ 100 Pcs
AST062	1/16"	100	1,000	0.12
AST078	5/64"	100	1,000	0.10
AST093	3/32"	100	1,000	0.28
AST125	1/8"	100	1,000	0.25
AST156	5/32"	100	1,000	0.44
AST187	3/16"	100	1,000	0.38
AST250	1/4"	100	1,000	1.90
AST312	5/16"	1	--	1.60



COPPER STOPS

Part #	Cable Size	Dealer Pack	Bulk	Wt (Lbs)/ 100 Pcs
CST047	3/64"	100	1,000	0.10
CST062	1/16"	100	1,000	0.22
CST093	3/32"	100	1,000	0.81
CST125	1/8"	100	1,000	0.72
CST156	5/32"	100	--	1.10
CST187	3/16"	100	--	1.10
CST250	1/4"	100	--	5.90
CST312	5/16"	100	--	5.50
CST375	3/8"	100	--	4.60

How To Use A
Hand Swager



Thin wall
for easier
swaging.



SSL062

Stops are
bevelled
on one side
for ease of
assembly.



AST250



CST093



Ben



NICOPRESS BLACK COPPER SLEEVES

Part #	Cable Size	Pcs/Pack	Wt (Lbs)/Ea
618-1-C	1/16"	1	0.01
618-3-M	1/8"	1	0.02
618-6-X	3/16	1	0.05
618-10-F6	1/4"	1	0.08



AN STAINLESS STEEL THIMBLES - TYPE 304

Part #	Cable Size	Pcs/Pack	Bulk	Wt (Lbs)/Ea
STAN062	1/16"	1	1,000	0.0015
STAN125	1/8"	1	1,000	0.0046



STANDARD DUTY STAINLESS STEEL THIMBLES - TYPE 304

Part #	Cable Size	Pcs/Pack	Wt (Lbs)/Ea
STH125SD	1/8"	1	0.005
STH156SD	5/32"	1	0.005
STH187SD	3/16"	1	0.015
STH250SD	1/4"	1	0.025
STH312SD	5/16"	1	0.040
STH375SD	3/8"	1	0.055
STH500SD	1/2"	1	0.094
STH625SD	5/8"	1	0.187
STH750SD	3/4"	1	0.312



HEAVY DUTY STAINLESS STEEL THIMBLES - TYPE 304

Part #	Cable Size	Pcs/Pack	Wt (Lbs)/Ea
STH250HD	1/4"	1	0.040
STH312HD	5/16"	1	0.115
STH375HD	3/8"	1	0.220
STH500HD	1/2"	1	0.480
STH625HD	5/8"	1	0.680



618-1-C



STAN062



STH312SD



STH250HD





AN THIMBLES - ZINC PLATED

Part #	Cable Size	Dealer Pack	Bulk	Wt (Lbs)/ 100 Pcs
TAN062	1/16"-5/64"	100	1,000	0.15
TAN093	3/32"-1/8"	100	1,000	0.46
TAN156	5/32"	100	1,000	0.66
TAN187	3/16"	100	1,000	0.98
TAN250	1/4"	100	500	1.80
TAN312	5/16"	100	500	4.00
TAN375	3/8"	100	500	7.70



TAN062



STANDARD DUTY THIMBLES - GALVANIZED

Part #	Cable Size	Dealer Pack	Bulk	Wt (Lbs)/ 100 Pcs
TSD125	1/8"	100	2,000	3.02
TSD187	3/16"	100	2,000	3.16
TSD250	1/4"	100	2,000	3.75
TSD312	5/16"	100	1,000	4.00
TSD375	3/8"	100	1,000	6.25
TSD500	1/2"	10	500	12.00
TSD625	5/8"	1	200	33.10
TSD750	3/4"	1	100	52.00



TSD125



HEAVY DUTY THIMBLES - GALVANIZED

Part #	Cable Size	Dealer Pack	Bulk	Wt (Lbs)/ 100 Pcs
THD187	3/16"	100	1,000	3.60
THD250	1/4"	100	1,000	6.20
THD312	5/16"	100	500	11.47
THD375	3/8"	50	250	24.00
THD500	1/2"	50	125	46.00
THD625	5/8"	10	25	69.00
THD750	3/4"	10	25	151.00
THD875	7/8"	1	25	178.00
THD100	1"	1	10	253.00



THD187





THIMBLE EYE STEEL SLINGS

Part #	Size x Length (Ft)	Rated Capacity (Lbs)		Wt (Lbs)/ Each
		Vertical	Basket	
7 x 19 Galvanized Cable Slings				
TCS375X1.5	3/8" x 1-1/2	2,700	5,400	1.23
TCS375X02.5	3/8" x 2-1/2	2,700	5,400	1.70
TCS375X05	3/8" x 5	2,700	5,400	2.10
TCS375X10	3/8" x 10	2,700	5,400	3.35
TCS375X20	3/8" x 20	2,700	5,400	5.75
TCS375X30	3/8" x 30	2,700	5,400	7.80
TCS375X50	3/8" x 50	2,700	5,400	13.60
6 x 19 IWRC Galvanized Wire Rope Slings				
TCS500X05	1/2" x 5	4,600	9,200	3.82
TCS500X10	1/2" x 10	4,600	9,200	6.20
TCS500X20	1/2" x 20	4,600	9,200	10.70
TCS500X30	1/2" x 30	4,600	9,200	15.30



TCS375X10



CABLE ACCESSORIES

Part #	Description	Bulk	Wt (Lbs)/Ea
ADJ	Cable Adjustment Clips	100	0.02
CC1	Keyhole Clip for Mini Milford Pin	100	0.05
SPOOL250	1/4" Cable Spool	100	0.006
SPOOL312	5/16" Bevelled Spool for U-Bolt	100	0.008
SPOOL437	7/16" Cable Spool for Over Roller Shaft	100	0.009



SPOOL250



CC1 cable termination fits mini Milford pin



CC1

ADJ clip for extension cable adjustment



ADJ



KWIC-LOC™

Part #	Cable Size	Minimum* Load (Lbs)	WLL (Lbs)	Pcs/Pk	Wt (Lbs)/Ea
KL50	3/64"	5	35	50	0.05
KL75	1/16"	10	75	50	0.05
KL100	3/32"	25	150	100	0.05
KL150	1/8"	25	250	50	0.13
KL200	3/16"	50	640	10	0.35
KL600	1/4"	50	1,100	10	0.47
KV100	3/32"	25	150	10	0.20

* Minimum initial load for locking mechanism to engage.



KL100



KV100



GRIPPLE PLUS

Part #	Description	Cable Size	WLL (Lbs)	Wt (Lbs)/Ea
GPLUS-SM	Gripple Plus Small	1/16" - 5/64"	660	0.04
GPLUS-M	Gripple Plus Medium	3/32" - 1/8"	880	0.05
GPLUS-L	Gripple Plus Large	5/32"	1320	0.07



GPLUS-SM



GRIPPLE TORQ TENSIONING TOOL

Part #	Ratio	Length	Wt (Lbs)/Ea
GT-TOOL	6:1	17"	3.00



GT-TOOL



ADJUSTMENT CLIPS - ZINC PLATED

Part #	Size	Pcs/Pack	Wt (Lbs)/Ea
CLIP3	2.5"	650	0.09



CLIP3



CABLE LOCKS

Part #	Cable Size	WLL (Lbs)	Wt (Lbs)/Ea
CABLELOCK062	1/16"	60	0.08
CABLELOCK125	1/8"	250	0.10



CABLELOCK062



CHAIN

FEHR CHAIN MEETS THE INDUSTRY NACM STANDARD.



GRADE 30 PROOF COIL CHAIN

Self Colored Part #	Zinc Plated Part #	Galvanized Part #	Size	WLL (Lbs)	Ft/Full Drum	Ft/Half Drum	Ft/Pail	Wt (Lbs)/Ft
12B125	--	--	1/8"	400	1,000	--	--	0.20
12B187	12E187	12H187	3/16"	800	1,500	750	250	0.40
12B250	12E250	12H250	1/4"	1,300	800	400	133	0.68
12B312	12E312	12H312	5/16"	1,900	550	275	92	1.20
12B375	12E375	12H375	3/8"	2,650	400	200	66	1.70
12B500	12E500	12H500	1/2"	4,500	200	100	35	2.70
--	--	12H625	5/8"	6,900	150	75	--	4.06
--	--	12H750	3/4"	10,600	100	50	--	6.00

- Grade 30 chain can be cut to length.



12B187
SELF COLORED



12E250
ZINC PLATED



12H312
HOT DIP GALVANIZED



Grade 30 proof coil steel chain is a light to medium duty chain used in the automotive and marine markets, security barriers, agriculture, and tow/logging. Proof Coil is available in electro-galvanized, hot galvanized or self-colored finishes.



GRADE 43 HIGH TEST CHAIN

Self Colored Part #	Galvanized Part #	Size	WLL (Lbs)	Ft/Full Drum	Ft/Half Drum	Ft/Pail	Wt (Lbs)/Ft
14B250	14H250	1/4"	2,600	800	400	133	0.66
14B312	14H312	5/16"	3,900	550	275	92	1.16
14B375	14H375	3/8"	5,400	400	200	66	1.82
14B500	14H500	1/2"	9,200	200	100	35	2.99

- Grade 43 chain can be cut to length.



SELF-COLORED



HOT DIP GALVANIZED

Watch video for more details about Grades of Chain





Long Link design allows for matched size shackle pins to go through mid links and the shackle body through the end link.



GALVANIZED HIGH TEST MOORING CHAIN

Part #	Size	WLL (Lbs)	Ft/Full Drum	Wt (Lbs)/Ft
14M375-0400	3/8"	4,050	400	1.30
14M500-0200	1/2"	6,900	200	2.39
14M625-0150	5/8"	9,750	150	3.30

- Minimum orders apply. Call 800.431.3095 for details and availability.



SSPC125



STAINLESS STEEL CHAIN - TYPE 316, HIGH STRENGTH

Part #	Size	WLL (Lbs)	Ft/Full Drum	Ft/Half Drum	Ft/Pail	Wt (Lbs)/Ft
SSPC125	1/8"	500	1,000	500	100	0.22
SSPC187	3/16"	1,200	1,000	500	100	0.45
SSPC250	1/4"	2,000	800	400	100	0.65
SSPC312	5/16"	2,800	550	275	100	0.97
SSPC375	3/8"	3,550	400	200	100	1.67
SSPC500	1/2"	6,500	200	100	Per Ft	2.25
SSPC625	5/8"	9,800	150	--	Per Ft	4.10
SSPC750	3/4"	15,000	50	--	Per Ft	5.30
SSPC100	1"	23,250	60	--	Per Ft	9.24

-Stainless steel chain can be cut to length.
 -Not rated for overhead lifting
 -Ask us about Grade 50/Grade 60 Chain for overhead Lifting

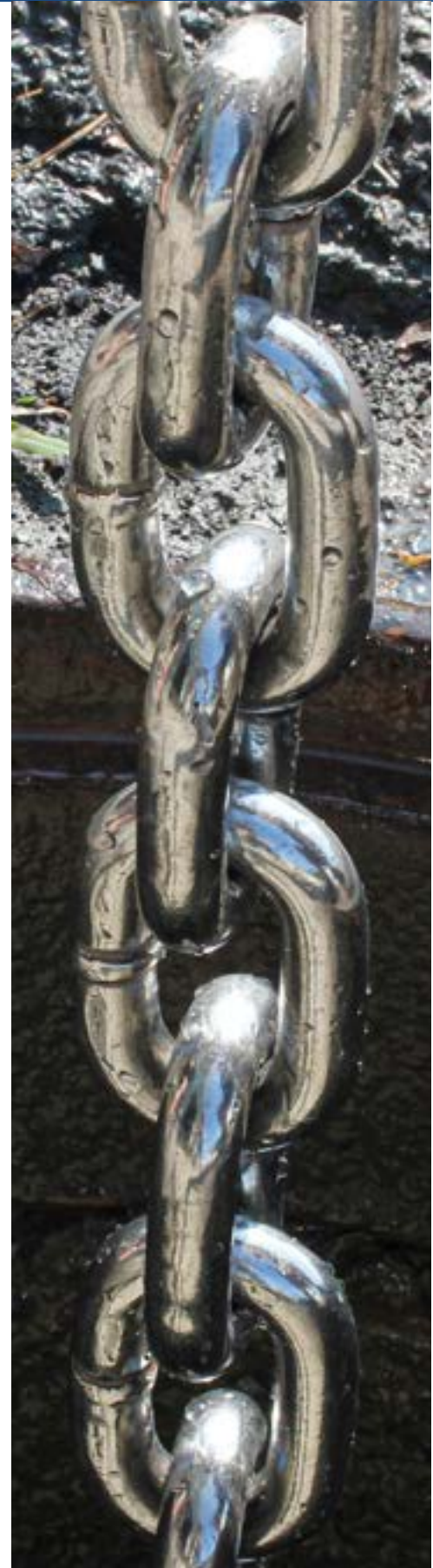



GRADE 70 TRANSPORT CHAIN - YELLOW ZINC CHROMATE FINISH

Part #	Size	WLL (Lbs)	Ft/Full Drum	Ft/Half Drum	Ft/Pail	Wt (Lbs)/Ft
17G250	1/4"	3,150	800	400	100	0.78
17G312	5/16"	4,700	550	275	100	0.95
17G375	3/8"	6,600	400	200	100	1.78
17G500	1/2"	11,300	200	100	--	2.13

- Fehr Grade 70 Transport Chain is anodized with yellow zinc chromate for easy identification.
- Meets DOT, CCMTA & CVSA for truck tie down usage.
- Grade 70 chain can be cut to length.



17G250



GRADE 80 ALLOY - DECK CHAIN

Part #	Size	Length/Ft	WLL (Lbs)	Wt (Lbs)/Ea
TAC500X003	1/2"	3	12,000	6.00
TAC500X005	1/2"	5	12,000	10.00



TAC500X003



GRADE 80 ALLOY CHAIN - BLACK E-COATED

Part #	Size	WLL (Lbs)	Ft/Full Drum	Ft/Half Drum	Ft/Pail	Wt (Lbs)/Ft
18S250 (USA)	9/32"	3,500	800	400	100	0.76
18S375 (USA)	3/8"	7,100	400	200	100	1.52
18S500 (USA)	1/2"	12,000	200	100	--	2.50
18S625 (USA)	5/8"	18,100	150	75	--	3.10
19S250	9/32"	3,500	800	400	100	0.76
19S375	3/8"	7,100	400	200	100	1.52

- Use only Grade 80 or Grade 100 Alloy Chain and fittings for overhead lifting.
- Grade 80 chain can be cut to length.



18S250



GRADE 100 ALLOY CHAIN

Part #	Size	Ft/Full Drum	WLL (Lbs)	Wt (Lbs)/Ft
20S250-0400	1/4"	400	4,300	0.782
20S312-0550	5/16"	550	5,700	1.00
20S375-0400	3/8"	400	8,800	1.55



20S250-0400





PASSING LINK CHAIN

Part #	Description	Finish	WLL (Lbs)	Pack	Wt (Lbs)/Ea
EGPL4-0X100	4/0 x 100 Ft	Zinc Plated	600	Carton	43



EGPL4-0X100



DOUBLE LOOP CHAIN

Part #	Description	Finish	WLL (Lbs)	Pack	Wt (Lbs)/Ea
EGDL4X100	#4 x 100 Ft	Zinc Plated	70	Carton	6
EGDL3X200	#3 x 200 Ft	Zinc Plated	90	Reel	13
EGDL2X200	#2 x 200 Ft	Zinc Plated	115	Reel	16
EGDL1X100	#1 x 100 Ft	Zinc Plated	155	Carton	10
EGDL2-0X250	2/0 x 250 Ft	Zinc Plated	255	Carton	43
SDL3X100	#3 x 100 Ft	304 Stainless	90	Carton	7
SDL1X100	#1 x 100 Ft	304 Stainless	155	Carton	9
SDL2-0X100	2/0 x 100 Ft	304 Stainless	255	Carton	17



EGDL4X100



STRAIGHT LINK CHAIN

Part #	Description	Finish	WLL (Lbs)	Pack	Wt (Lbs)/Ea
EGSLC2/0X100	2/0 x 100 Ft Coil	Zinc Plated	520	Carton	28
EGSLM4X100	#4 x 100 Ft Machine	Zinc Plated	215	Carton	12
EGSLM2X100	#2 x 100 Ft Machine	Zinc Plated	325	Carton	19
EGSLM2/0X100	2/0 x 100 Ft Machine	Zinc Plated	545	Carton	31



COIL



MACHINE





THEATRICAL RIGGING CHAIN - BLACK ALLOY

Part #	Description	Inside Length	Inside Wide	WLL (Lbs)	Wt (Lbs)/Ft
13BL281-0100	9/32 x 100Ft	1.24"	0.49"	3,250	0.65
13BL281-0800	9/32 x 800 Ft	1.24"	0.49"	3,250	0.65



13BL281-0100



SINGLE JACK CHAIN

Part #	Description	Finish	WLL (Lbs)	Pack	Wt (Lbs)/Ea
EGSJ16X250	#16 x 250 Ft	Zinc Plated	10	Reel	8
EGSJ12X250	#12 x 250 Ft	Zinc Plated	29	Reel	25
EGSJ10X250	#10 x 250 Ft	Zinc Plated	43	Reel	38
EGSJ8X250	#8 x 250 Ft	Zinc Plated	60	Reel	50
SSJ14X100	#14 x 100 Ft	304 Stainless	16	Carton	5
SSJ12X100	#12 x 100 Ft	304 Stainless	29	Carton	9



EGSJ10X250



SASH CHAIN

Part #	Description	Finish	WLL (Lbs)	Pack	Wt (Lbs)/Ea
EGSASH35X100	#35 x 100 Ft	Zinc Plated	105	Reel	6
EGSASH8X500	#8 x 500 Ft	Zinc Plated	75	Carton	20
SASH9BAG	#8 x 4.5 Ft	Zinc Plated	75	Bag	20
SASH16BAG	#8 x 8 Ft	Zinc Plated	75	Bag	20
SSSASH35X100	#35 x 100 Ft	304 Stainless	105	Reel	6



EGSASH8X500



Kerry



Mark

FEHR LOAD BINDERS MEET DOT, CCMTA AND CVSA REQUIREMENTS FOR TRUCK TIE DOWN USAGE.



LOAD BINDERS

Part #	Size	Type	Chain Size/Grade	WLL (Lbs)	Wt (Lbs)/Ea
LBNDR250	1/4"	Lever	1/4" G30, 1/4" G43	2,600	3
LBNDR375	5/16" - 3/8"	Lever	5/16" G 70, 3/8" G43	5,400	8
LBNDR500	3/8" - 1/2"	Lever	3/8" G 70, 1/2" G43	9,200	16
RLBNDR375	5/16" - 3/8"	Ratchet	5/16" G70, 3/8" G43	5,400	11
RLBNDR500	3/8" - 1/2"	Ratchet	3/8" G70, 1/2" G43	9,200	12
RLBNDR625	1/2" - 5/8"	Ratchet	1/2" G70, 5/8" G43	13,000	16

Lever type



RLBNDR375

Ratchet type



LBNDR500



BINDER CHAINS

Part #	Size	Type	Chain	WLL (Lbs)	Wt (Lbs)/Ea
HTTC375X16	3/8" x 16'	Clevis Grab Hooks	G43 High Test	5,400	25
HTTC375X20	3/8" x 20'	Clevis Grab Hooks	G43 High Test	5,400	31
G7TC375X16FT	3/8" x 16'	Clevis Grab Hooks	G70 Transport	6,600	27
G7TC375X20	3/8" x 20'	Clevis Grab Hooks	G70 Transport	6,600	32

High Test with zinc plated clevis grab hooks.



HTTC375X20

Grade 70 Transport with yellow dichromate finish for easy identification.



G7TC375X16FT



GRADE 80 HAMMERLOCKS

Part#	Size	Finish	WLL (Lbs)	Wt/Ea
HL281	1/4"	Painted	3,250	0.25
HL375	3/8"	Painted	7,100	1.00
HL500	1/2"	Painted	12,000	2.00
HL625	5/8"	Painted	18,000	3.00

- Stainless Steel Hammerlocks available by special order. Call 800.431.3095 for details.



HL281



FORGED ALLOY OVAL RINGS

Part #	Size	Finish	WLL (Lbs)	Wt/Ea
ML500	1/2"	Painted	7,400	0.89
ML625	5/8"	Painted	9,000	1.52
ML750	3/4"	Painted	12,300	2.14



ML750



ALLOY GRAB LINKS

Part #	Chain Size	Size (A)	Inside Length (B)	Inside Width (C)	Throat Opening (D)	Finish	WLL (Lbs)	Wt (Lbs)/ Ea
KEYHOOK	1/4"-1/2"	3/4"	5-1/2"	2-1/4"	9/16"	Painted	7,300	4.00
KEYHOOK-625	5/8"	1"	7-1/2"	3-7/16"	7/8"	Painted	18,100	4.65
KEYHOOK-750	3/4"	1-3/8"	11-1/4"	6"	1-1/8"	Painted	28,300	14.30
KEYHOOK-100	1"	1-3/4"	13-3/4"	7"	1-1/2"	Painted	47,700	26.70

Alloy Chains - Pg. 29 & 31
Alloy Hooks - Pg. 64

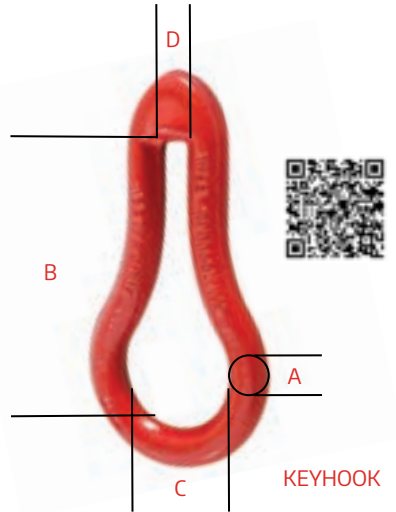

BEAM CLAMPS

Part #	Safe Working Load (Tons)	Fits Beam Widths	Wt (lbs)/Ea
LMBC-1	1	3" - 9"	9
LMBC-2	2	3" - 9"	11
LMBC-3	3	3.2" - 12.6"	23
LMBC-5	5	3" - 12"	25.5

Fits wide range of beam sizes. Rugged all steel construction, and black finish.



LMBC-1



PLAS250X30
SINGLE LEG



PLAD250X30
DOUBLE LEG



GRAB LINK ASSEMBLIES - TYPE 316

Single Leg Part#	Double Leg Part#	Chain Size	Chain WLL (Lbs)	Shackle Size	Shackle WLL (Lbs)	Grab Link WLL (Lbs)
PLAS250	PLAD250	1/4"	2,000	5/16"	1,375	7,300
PLAS312	PLAD312	5/16"	2,800	3/8"	2,365	7,300
PLAS375	PLAD375	3/8"	3,550	1/2"	3,400	7,300
PLAS500	PLAD500	1/2"	6,500	5/8"	5,500	7,300
PLAS625	PLAD625	5/8"	9,800	3/4"	7,700	18,100
PLAS750	PLAD750	3/4"	15,000	7/8"	8,000	28,300
PLAS100	PLAD100	1"	23,250	1-1/8"	12,000	47,700



SINGLE LEG CHAIN SLING - TYPE 316

Part#	Chain Size	Chain WLL (Lbs)	Shackle Size	Shackle WLL (Lbs)	Overall Length (Ft)
PLSB250X1	1/4"	2,000	5/16"	1,375	1
PLSB312X1	5/16"	2,800	3/8"	2,365	1
PLSB375X1	3/8"	3,550	1/2"	3,400	1
PLSB500X1	1/2"	6,500	5/8"	5,500	1
PLSB625X1	5/8"	9,800	3/4"	7,700	1
PLSB750X1	3/4"	15,000	7/8"	8,000	1
PLSB100X1	1"	23,250	1-1/8"	12,000	1



PLSB250X1



DOUBLE LEG CHAIN SLING - TYPE 316

Part#	Chain Size	Chain WLL (Lbs)	Shackle Size	Shackle WLL (Lbs)	Overall Length (Ft)
PLDB250X2	1/4"	2,000	5/16"	1,375	2
PLDB312X2	5/16"	2,800	3/8"	2,365	2
PLDB375X2	3/8"	3,550	1/2"	3,400	2
PLDB500X2	1/2"	6,500	5/8"	5,500	2
PLDB625X2	5/8"	9,800	3/4"	7,700	2
PLDB750X2	3/4"	15,000	7/8"	8,000	2
PLDB100X2	1"	23,250	1-1/8"	12,000	2



PLDB250X2



- Grab Link Assemblies and Chain Slings are custom made. Call 800.431.3095 for details.
 - Assemblies maximum working load not to exceed the WLL of weakest component. keyhole grab is painted alloy steel.



HIT® CABLE & WIRE ROPE CUTTERS

Part #	Description	Length	Cable Size	Wt (Lbs)/Ea
TRC8	HWC6 Cable Cutter	7.5"	1/64"-3/16"	0.75
THWC9*	HWC9 Cable Cutter	13"	1/8"-11/32"	1.80
THWC12*	HWC12 Cable Cutter	20"	1/8"-1/2"	3.80
THWC16*	HWC16 Cable Cutter	26"	1/8"-5/8"	6.20
TWRC21B	Bench Mount Cutter	21"	1/8"-3/8"	11.00
TWRC21B-BLADES	Replacement Blades for Bench Mount Cutter	--	Up to 3/8"	1.00
TRC450	22-WC24 Cable Cutter	24"	1/8"-3/8"	5.25
TRC800	22-WC36 Cable Cutter	36"	1/8"-5/8"	12.00

*Replacement blades are available.



TRC8



THWC16



TWRC21B



TRC450



HIT® CHAIN & BOLT CUTTERS

Part #	Description	Length	Cuts Up To	Wt (Lbs)/Ea
TH22-CC24P	HIT Chain Cutter	24"	3/8" Non-Alloy	6.3
TH22-CC42P	HIT Chain Cutter	42"	1/2" Non-Alloy	20.0
TH22-BC24H	HIT Center Cut Bolt Cutter	24"	3/8"	5.5



TH22-CC24P



TH22-CC42P



TH22-BC24H



HIT® GUY WIRE CUTTER

Part #	Description	Length	Max. Cable Size	Wt (Lbs)/Ea
TH22-GC30	Guy Wire Cutter	30"	3/8"	9.25



TH22-GC30



HIT® BATTERY CABLE CUTTER

Part #	Description	Length	Max. Cable Size	Wt (Lbs)/Ea
TH29-CC24	8 Ton Battery Cable Cutter	14"	15/16"	9.00



TH29-CC24



HIT® CABLE SWAGERS

Part #	Description	Length	Cable Size	Wt (Lbs)/Ea
THSC21B	5 Cavity Bench Swager	20.5"	1/16" - 3/16"	11
THSC350	3 Cavity Swager	14"	1/16", 3/32", 1/8"	3.50
THSC600	5 Cavity Swager	24"	1/16", 3/32", 1/8", 5/32", 3/16"	5.50
THSC600B	5 Cavity Swager	24"	1/16", 3/32", 1/8", 5/32", 3/16"	5.60
THS1000	3 Cavity Swager	30"	5/32", 1/4", 5/16"	19.00
TSW031-062	3 Cavity Mini Swager	9"	1/32", 3/64", 1/16"	0.75
TSW375	1 Cavity Swager	36"	3/8"	14.50



TSW031-062

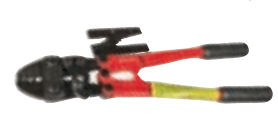

THSC350



THSC600



THSC600B



THS1000



TSW375



NICOPRESS CABLE SWAGERS

Part #	Description	Length	Cable Size	Wt (Lbs)/Ea
T5606	Battery Powered Compression Tool	20.5"	3/64" to 3/8"	8.00
T3V-F6-XM	3 Cavities Swager	34-1/2"	1/8", 3/16", 1/4"	14.00
T5606-OVAL-M	6 - Oval - M Die	-	1/8"	1.00
T5606-OVAL-X	6 - Oval - M Die	-	3/16"	1.00



T5606



T3V-F6-XM



T5606-OVAL-M



FELCO® CABLE & WIRE ROPE CUTTERS

Part #	Description	Length	Cable Size	Wt (Lbs)/Ea
TFC7	Felco C-7 Cable Cutter	8"	1/64"-3/16"	0.75
TFC9	Felco C-9 Cable Cutter	13"	1/8"-1/4"	1.87
TFC12	Felco C-12 Cable Cutter	23"	1/8"-3/8"	4.75
TFC16	Felco C-16 Cable Cutter	23"	1/8"-5/8"	6.00



TFC7



TFC9



TFC16



TFC12



LOCOLOC SWAGING TOOLS **MADE IN USA**

Part #	Description	Length	Cable Size	Wt (Lbs)/Ea
1SC	Multi Cavity Swager	26"	1/16", 3/32", 1/8", 5/32", 3/16"	6.50
1BSC	Bench Multi Cavity Swager	22.5"	1/16", 3/32", 1/8", 5/32", 3/16"	6.60
1SC-3	3 Cavity Hand Swager	17"	3/32", 1/8" 3/16"	6.00
L-250	Single Cavity Hand Swager	28"	1/4"	5.50
TGA-1P	Go-No Go Gauge	3.5"	1/16", 3/32", 1/8", 5/32", 3/16"	0.16
TGA-2P	Go-No Go Gauge	3.5"	3/16", 7/32", 1/4", 5/16"	0.13



1SC



L-250



1SC-3



1BSC



TGA-1P



TGA-2P



Watch video for more details about Tool Bag



FEHR MINI SWAGE TOOL

Part #	Description	Length	Cable Size	Wt (Lbs)/Ea
TI7	Wire Cutter	7.68"	Up to 3/16 Steel Cable	0.77
TI062	Mini Hand Swager	9.85"	1/32", 3/64", 1/16"	0.70
TSPOUCH	Rigging Tool Pouch	11"	--	0.60
TGA-4P	Stainless Go / No Go Gauge		1/32" - 3/16"	0.16



TGA-4P



TI7



TI062



SWAGING KITS

Part #	Description	Swager	Cutter	Fittings	Case	Length	Wt (Lbs)/Ea
TSWAGEKIT	5 Cavity	HSC-600	RC-8	Aluminum	Metal Case	24"	22.50
1SCKIT	5 Cavity	1SC	FELCO C7	Aluminum	Metal Case	24"	24.20
1SCKIT-COPPER	5 Cavity	1SC	FELCO C7	Copper	Metal Case	24"	29.50
THSC600KIT	5 Cavity	HSC-600	RC-8	Aluminum	Soft Bag	25"	17.40
TS600BOX	Metal Case Only	--	--	--	--	24"	12.70
TS600BAG	Polyester Tool Bag	--	--	--	--	25"	3.65
TI062-KIT	Mini Hand Swaging Tool Kit	TI062	TI7	Aluminum	Denier Polyester Pouch	11"	2.60

- Swaging tool in kits will crimp 1/16", 3/32", 1/8", 5/32", 3/16" fittings.

Includes case, swager, cutter, no-go gauge, 100 pcs ea 1/16", 3/32", 1/8", 5/32", 3/16" sleeves, 100 pcs ea 3/32", 1/8" stops.



TSWAGEKIT

Same components as TSWAGEKIT in a soft tool bag.



THSC600KIT



TI062-KIT



TS600BAG



KLEIN GRIPS - CHICAGO™ **MADE IN USA**



CP1613-30



CP1613-40



Part #	Minimum Cable Size	Maximum Cable Size	WLL (Lbs)	Wt (Lbs)/Ea
CP1613-30	0.080"	0.200"	1,500	1.50
CP1613-40	0.120"	0.370"	4,500	3.00
CP1659-20	0.200"	0.420"	4,500	3.00
CP1692-5	0.218"	0.550"	8,000	6.40



KLEIN GRIPS - HAVEN™ **MADE IN USA**



CP1659-20



CP1692-5



Part #	Minimum Cable Size	Maximum Cable Size	WLL (Lbs)	Wt (Lbs)/Ea
CP1604-20	0.125"	0.500"	5,000	2.08
CP1604-20L*	0.125"	0.500"	5,000	2.08
CP1625-20*	0.280"	0.750"	8,000	4.00

*With latch.



CP1604-20



CP1604-20L



CP1625-20



*Check website for more items offered by Klein tools. Call 800.431.3095 for details.



IMPORTED CABLE GRIPS



WGRIP093-187



WGRIP125-500



Part #	Minimum Cable Size	Maximum Cable Size	WLL (Lbs)	Wt (Lbs)/Ea
WGRIP093-187	0.930"	0.187"	1,500	1.54
WGRIP125-500	0.125"	0.500"	4,600	2.64
WGRIP125-500-WL*	0.125"	0.500"	4,600	3.30
WGRIP156-875	0.156"	0.875"	4,400	3.09

*With latch.



WGRIP125-500-WL



WGRIP156-875



MAASDAM POW'R-PULL® MADE IN USA



Part #	Description	Cable Lift (Ft)	Ratio	Wt (Lbs)/Ea
MAA144S-6	1 Ton Cable Puller	12	15:1	7.60
MAA144SB-6	2 Ton Cable Puller	6	30:1	8.80



MAA144S-6



MAA144SB-6



DIGITAL ELECTRONIC CALIPER

Part #	Description	Size Range	Wt (Lbs)/Ea
CALIPER	Measures in metric or inches	0" - 6"	0.25

Has a 6"/150mm measuring range, 0.0005"/0.01mm resolution for long life.



CALIPER



How to Measure Cable Diameter

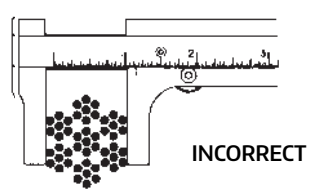
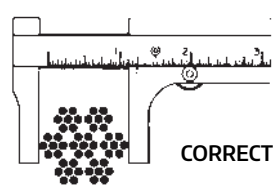



ROPE & CABLE METER

Part #	Model	Capacity	Wt (Lbs)/Ea
TM1410	No. 1410	1/64" - 7/8"	6

- Metric model is available by request. Call 800.431.3095 for details.

Measures up to 9,999 ft., maximum speed of 1,000 ft/min.



TM1410



RONAN™ CUTTER & ACCESSORIES

Part #	Description	Quantity	Wt (Lbs)/Ea
RON401	3-7/8" Ronan Multi-Cut	1	1.33
RON40178	Replacement Blades for 401	3	0.10
RON40278	Stainless Blades for 401	3	0.17

RON401 is ideal for 2" weatherseal, cuts through body and flex with one cut



RON401



W HOP CLIPS & APPLICATOR

Part #	Wt (Lbs)/Ea
W-HOPCLIP	0.01
W-HOPCLIP-TOOL	2.80
W-HOPCLIP-TOOLTIP	0.55



W-HOPCLIP



Coconut Hop Coir
*COIRTWINEHS



W-HOPCLIP-TOOL



W-HOPCLIP-TOOLTIP

*Seasonal order. Call 800.431.3095 to preorder.



UL APPROVED EXTENSION CORDS

Part #	Description	Length	Gauge	Pack	Wt (Lbs)/Ea
ELC14-3X003	Extension Cord	3'	14	1	0.37
ELC14-3X006	Extension Cord	6'	14	1	0.70
ELC14-3X009	Extension Cord	9'	14	1	0.90
ELC16-3X025	Extension Cord	25'	16	1	1.83



ELC14-3X006



ELC16-3X025



TORSION SPRING REPAIR BLOCKS

Part #	Description	Size	Pcs/Bg	Wt (Lbs)/Bg
TSRB-BLUE	Blue Temporary Repair Block	.207-.3065	2	0.55
TSRB-RED	Red Temporary Repair Block	.375-.4305	2	0.55
TSRB-YELL	Yellow Temporary Repair Block	.3175-.3625	2	0.55



TSRB



TORSION SPRING TOOLS

Part #	Description	Size	Wt (Lbs)/Ea
TSGA-RULER	Fehr Ruler Type Spring Gauge	.125-.625	0.14
TSGA-UNI	Commercial Pocket Wire Gauge	.1875-.500	0.3
TS-ST	Torsion Spring Spreader Tool	-	0.46
SAFETYCOLLAR	Torsion Spring Safety Collar	-	0.02
WINDINGBAR18	1/2" x 18" Winding Bar (1 Pc)	18"	1.0
WINDINGBAR	1/2" X 24" Winding Bar (1 Pc)	24"	1.34

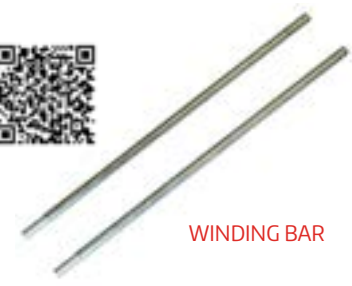

WINDING BAR



TS-ST



SAFETY COLLAR



TSGA-RULER



TSGA-UNI



ANGLE SHEAR

Part #	Description	Cuts Angle Up To	Wt (Lbs)/Ea
TRWAC-4	Roper Whitney #4 Angle Cutter Includes Handle	2" x 2" x 1/4"	51.00
TRWAC-4HANDLE	Roper Whitney #4 6 Ft. Replacement Handle	-	22.00
TRWACBLADE-B	Roper Whitney 2 Pc Base Blade	-	0.40
TRWACBLADE-S	Roper Whitney 1 Pc Shear Blade	-	0.35
THDPRO	HD Pro Angle Cutter	2"x2" 12 Gauge	0.22



TRWAC-4



THDPRO



TRWACBLADE-B



TRWACBLADE-S

THE TUFLEX® DIFFERENCE

TUFLEX® ROUNDSLINGS ARE ENDLESS SYNTHETIC SLINGS MADE FROM SKEINS (CONTINUOUS LOOPS OR HANKS) OF POLYESTER YARN COVERED BY DOUBLE WALLED TUBULAR JACKETS. **MADE IN THE USA.**



LIFTALL ROUND SLINGS

Part #	Length	Color	Rated Capacities (Lbs)			Wt (Lbs)/Ea
			Vertical	Choker	Basket	
EN30X02	2'	Purple	2,600	2,100	5,200	0.40
EN30X03	3'	Purple	2,600	2,100	5,200	0.60
EN30X04	4'	Purple	2,600	2,100	5,200	0.80
EN30X06	6'	Purple	2,600	2,100	5,200	1.20
EN30X08	8'	Purple	2,600	2,100	5,200	1.60
EN30X10	10'	Purple	2,600	2,100	5,200	2.00
EN60X02	2'	Green	5,300	4,200	10,600	0.60
EN60X03	3'	Green	5,300	4,200	10,600	0.90
EN60X04	4'	Green	5,300	4,200	10,600	1.20
EN60X06	6'	Green	5,300	4,200	10,600	1.80
EN60X08	8'	Green	5,300	4,200	10,600	2.40
EN60X10	10'	Green	5,300	4,200	10,600	3.00
EN90X04	4'	Yellow	8,400	6,700	16,800	2.00
EN90X06	6'	Yellow	8,400	6,700	16,800	3.00
EN90X08	8'	Yellow	8,400	6,700	16,800	4.00
EN90X10	10'	Yellow	8,400	6,700	16,800	5.00
EN90X12	12'	Yellow	8,400	6,700	16,800	6.00
EN150X05	5'	Red	13,200	10,600	26,400	4.00
EN150X06	6'	Red	13,200	10,600	26,400	4.80
EN150X08	8'	Red	13,200	10,600	26,400	6.40
EN150X10	10'	Red	13,200	10,600	26,400	8.00
EN150X12	12'	Red	13,200	10,600	26,400	9.60
EN150X15	15'	Red	13,200	10,600	26,400	12.00

- Additional types and sizes available. Call 800.431.3095 for details.



POLYESTER STAGE ROUNDSLINGS - BLACK

Part #	Description	Length	Rated Capacities (Lbs)			Wt (Lbs)/Ea
			Vertical	Choker	Basket	
NSE30X03B	EN30	3'	2,600	2,100	5,200	0.60
NSE30X06B	EN30	6'	2,600	2,100	5,200	1.20
NSE30X09B	EN30	9'	2,600	2,100	5,200	1.80
NSE60X1.5B	EN60	1.5'	5,300	4,200	10,600	0.59
NSE60X03B	EN60	3'	5,300	4,200	10,600	0.90
NSE60X04B	EN60	4'	5,300	4,200	10,600	1.20
NSE60X06B	EN60	6'	5,300	4,200	10,600	1.80
NSE60X08B	EN60	8'	5,300	4,200	10,600	2.40
NSE60X09B	EN60	9'	5,300	4,200	10,600	2.70

44

Polyester slings are very strong and lightweight, ideal for suspension of stage, sound, and lighting equipment.



NSE30



NSE60



STEELFLEX POLYESTER ROUND SLINGS - BLACK

Part #	Description	Length	Rated Capacities in Lbs			Wt (Lbs)/Ea
			Vertical	Choker	Basket	
NSE60X03B-GAC	EN60	3'	5,300	4,200	10,600	2.00
NSE60X04B-GAC	EN60	4'	5,300	4,200	10,600	3.30
NSE60X06B-GAC	EN60	6'	5,300	4,200	10,600	4.00
NSE60X09B-GAC	EN60	9'	5,300	4,200	10,600	7.00



Made from galvanized steel cable in an endless configuration, encased in a double wall polyester jacket. Highly flexible and easy to use.



NSE60X03B-GAC





TUFF-EDGE® III WEB SLINGS - SINGLE PLY

Part #	Width	Length	Rated Capacities (Lbs)			Wt (Lbs)/Ea
			Vertical	Choker	Basket	
EE1801TFX3	1"	3'	1,600	1,280	3,200	0.40
EE1801TFX4	1"	4'	1,600	1,280	3,200	0.50
EE1801TFX6	1"	6'	1,600	1,280	3,200	0.90
EE1801TFX10	1"	10'	1,600	1,280	3,200	1.50
EE1801TFX12	1"	12'	1,600	1,280	3,200	1.80
EE1802TFX3	2"	3'	3,200	2,500	6,400	0.50
EE1802TFX4	2"	4'	3,200	2,500	6,400	0.60
EE1802TFX6	2"	6'	3,200	2,500	6,400	1.00
EE1802TFX10	2"	10'	3,200	2,500	6,400	1.70
EE1802TFX12	2"	12'	3,200	2,500	6,400	2.00



TUFF-EDGE® III WEB SLINGS - TWO PLY

Part #	Width	Length	Rated Capacities (Lbs)			Wt (Lbs)/Ea
			Vertical	Choker	Basket	
EE2801TFX3	1"	3'	3,200	2,500	6,400	0.40
EE2801TFX4	1"	4'	3,200	2,500	6,400	0.60
EE2801TFX6	1"	6'	3,200	2,500	6,400	0.80
EE2801TFX10	1"	10'	3,200	2,500	6,400	1.30
EE2801TFX12	1"	12'	3,200	2,500	6,400	1.60
EE2802TFX3	2"	3'	6,400	5,000	12,800	0.90
EE2802TFX4	2"	4'	6,400	5,000	12,800	1.20
EE2802TFX6	2"	6'	6,400	5,000	12,800	1.70
EE2802TFX10	2"	10'	6,400	5,000	12,800	2.70
EE2802TFX12	2"	12'	6,400	5,000	12,800	3.20



EE1801TFX10



Tuff-Edge® III Polyester Web Slings are stronger and have better edge cut resistance. You can expect longer sling life and lower overall costs when you switch to Tuff-Edge® III slings. Resistance to the two properties that can rapidly degrade webbing, abrasion and edge cutting, is greatly improved with the use of Tuff-Edge® III webbing.

- Additional types and sizes available. Call 800.431.3095 for details.





BLOCKS - TYPE 305 STAINLESS STEEL

Part #	Description	Sheave Diameter (mm)	WLL (Lbs)	Wt (Lbs)/Ea
S210-75	Open Block - Single Sheave, Swivel Eye	75	1,930	2.30
S212-75	Snatch Block - Single Sheave with Latch, Swivel Eye	75	3,050	3.20
S313-50	Square Block - Single Sheave, Swivel Eye	50	1,635	1.30
S313-75	Square Block - Single Sheave, Swivel Eye	75	2,480	2.10
S313-100	Square Block - Single Sheave, Swivel Eye	100	4,180	4.40
S314-25	Round Block - Single Sheave, Swivel Eye	25	825	0.30
S314-32	Round Block - Single Sheave, Swivel Eye	32	935	0.30
S314-50	Round Block - Single Sheave, Swivel Eye	50	1,540	0.90
S315-32	Round Block - Double Sheave, Swivel Eye	32	1,265	0.60
S315-50	Round Block - Double Sheave, Swivel Eye	50	1,890	1.45



S210



S212



S313



S314



S315



SHEAVES - TYPE 304 STAINLESS STEEL

Part #	Sheave Diameter (mm)	Bore Diameter (mm)	Wt (Lbs)/Ea
SSHV50	50	10	0.31
SSHV75	75	13	0.63
SSHV100	100	17	1.22



Hot dipped galvanized for superior corrosion protection, grease fittings, roller bearings.



YB3



Scott



YARDING BLOCKS - GALVANIZED

Part #	Sheave Diameter	Wire Rope Diameter	WLL (Tons)	Wt (Lbs)/Ea
YB3	3"	1/8" - 1/4"	1.50	3.50
YB4	4"	1/4" - 3/8"	3.00	5.50
YB5	5"	3/8" - 1/2"	4.50	9.50
YB6	6"	3/8" - 9/16"	6.00	16.50



PUL-4500WNB



PULLEYS

Part #	Pulley Diameter	Bearing	Material	Pieces/Ctn	Wt (Lbs)/Ctn
PUL-2500	3-1/2"	Bearingless	Plastic	50	37.50
PUL-2500W	3-1/2"	Bearingless	Nylon	50	37.50
PUL-4500	3-1/2"	Bearingless	Cast Iron	25	37.50
PUL-4500WNB	3-1/2"	Needle Bearing	Cast Iron	25	58.00



PUL-2500



PUL-2500W



PUL-4500



SPUL-1500



SPUL-2500



SPUL-2500WBRG



SPLIT BRACKET PULLEYS

Part #	Pulley Diameter	Pulley	Bracket	Pieces/Pack	Wt (Lbs)/Carton
SPUL-1500	1-1/2"	Zinc Plated	Zinc Plated	250	56
SPUL-2500	2-1/2"	Zinc Plated	Zinc Plated	50	60
SPUL-2500WBRG (w/ bearing)	2-1/2"	Zinc Plated	Zinc Plated	50	29
NP1500-SB	1-7/8"	Nylon	Zinc Plated	200	28
NP1500-SBSS	1-7/8"	Nylon	Stainless Steel	200	28
NP2500-SBSS	2-1/2"	Nylon	Stainless Steel	100	26



NP1500-SB



NP1500-SBSS



NP2500-SBSS



SWIVEL EYE PULLEYS

Part #	Sheave Diameter	Pulley	Bracket	Pieces/Pack	Wt (Lbs)/Carton
NPUL-0750	7/8"	Nylon	Zinc Plated	500	23
NPUL-0750SS	7/8"	Nylon	Stainless Steel	500	21
NPUL-1750	1-7/8"	Nylon	Zinc Plated	200	33



NPUL-0750



NPUL-0750SS



NPUL-1750



HB4



Lenny



HAY FORK PULLEYS WITH SWIVEL EYE - GALVANIZED

Part #	Sheave Diameter	Wire Rope Diameter	WLL (Tons)	Wt (Lbs)/Ea
HB4	4"	1/2"	1	6.00



CEILING WINCH

Part #	Type	Capacity (Lbs)	Drum Capacity	Ratio	Wt (Lbs)/Ea
HB5000	Split Drum	5,000	1/8" x 100 Ft	90:1	23

Used for double pull applications, including poultry feed lines and nests. This winch can replace the work of two conventional winches.



HB5000



WORM GEAR WINCHES

Part #	Type	Capacity (Lbs)	Drum Capacity	Ratio	Wt (Lbs)/Ea
WGW1500A	Single Drum	1,500	1/8" x 57 Ft	41:1	8.8
WGW1500AB	Double Drum	1,500	1/8" x 57 Ft	41:1	8.9
WGW2000A	Single Drum	2,000	1/8" x 57 Ft	41:1	9.0
WGW2000AB	Double Drum	2,000	1/8" x 57 Ft	41:1	9.2



WGW1500A



WGW1500AB





HAND WINCHES

Part #	Hub Diameter	Capacity (Lbs)	Drum Capacity	Ratio	Pieces/Master Carton	Wt (Lbs)/Ea
RW800	1"	800	5/32" x 33 Ft	3.2:1	12	4.0
RW1000	1"	1,000	5/32" x 33 Ft	4.1:1	8	6.5
RW1200	1"	1,200	3/16" x 33 Ft	4.1:1	8	7.0
RW1200LH	2"	1,200	5/32" x 33 Ft	4.1:1	8	7.2
RW1400	1"	1,400	3/16" x 33 Ft	4:1	8	8.0
RW2500	1"	2,500	3/16" x 33 Ft	4:1/8:1	4	10.5



RW800



RW1000



RW1200LH



RW2500



HAND WINCH - DUTTON LAINSON **MADE IN USA**



DL1100

Part #	Hub Diameter	Capacity (Lbs)	Drum Capacity	Ratio	Wt (Lbs)/Ea
DL1100	1"	1,100	3/16" x 79 Ft	3.7:1	6.0
DL1300LH	1-7/8"	1,300	3/16" x 66 Ft	3.7:1	6.6

- Full line of Dutton Lainson winches available. Please call 800.431.3095 for information.



Watch video for more details about Anchors



GALVANIZED NO WRENCH EARTH ANCHORS - HELIX

Part #	Length	Rod Diameter	Helix Diameter	Holding Strength (Lbs)*			Wt (Lbs)/Ea
				Class 5	Class 6	Class 7	
HELIX4-54	54"	0.75"	4"	4,500	3,000	1,500	9.0
HELIX6-66	66"	0.75"	6"	6,500	5,000	2,500	12.0
HELIX8-66	66"	1.00"	8"	11,000	9,000	6,000	19.0
HELIX10-66	66"	1.25"	10"	13,000	10,000	7,000	28.8
HELIX10-96	96"	1.25"	10"	13,000	10,000	7,000	42.0

Soil classification:

Class 5: Medium dense coarse sand and sandy gravels; stiff to very stiff silts and clay saprolites, residual soils.

Class 6: Loose to medium dense fine to coarse sand; stiff clays & silts; dense hydraulic fills; residual soils.

Class 7: Loose fine sands; Alluvium; loess; stiff and varied clays; flood plain soils; lake clays; adobe; gumbo; fill.

*Holding strengths are approximate and depend on soil density and conditions.

Auger anchors must be screwed deeply into the ground and installed in line with the direction of the guy load.



HELIX6-66



HELIX6-48



PAINTED NO WRENCH EARTH ANCHORS - HELIX

Part #	Length	Rod Diameter	Helix Diameter	Finish	Wt (Lbs)/Ea
HELIX15-4	15"	0.500"	4"	Painted	1.0
HELIX30-4	30"	0.500"	4"	Painted	2.0
HELIX40-6	40"	0.625"	6"	Painted	3.5
HELIX6-48	48"	0.625"	6"	Painted	7.0



Paul

FEHR FORGED TURNBUCKLES MEET THE PERFORMANCE REQUIREMENTS OF ASTM SPECIFICATION F1145-05, AND HAVE A MINIMUM SAFETY DESIGN FACTOR OF 5 : 1.



EYE/EYE TURNBUCKLES - DROP FORGED, HOT GALVANIZED

Part #	Size x Take Up	Eye Dim (A)	Eye Dim (B)	WLL (Lbs)	Wt (Lbs)/Ea
9EE250X04	1/4" x 4"	0.81"	0.34"	500	0.30
9EE312X04	5/16" x 4-1/2"	0.95"	0.44"	800	0.55
9EE375X06	3/8" x 6"	1.13"	0.53"	1,200	0.90
9EE500X06	1/2" x 6"	1.41"	0.71"	2,200	1.50
9EE500X09	1/2" x 9"	1.41"	0.71"	2,200	2.00
9EE500X12	1/2" x 12"	1.41"	0.71"	2,200	2.20
9EE625X06	5/8" x 6"	1.80"	0.88"	3,500	2.63
9EE625X09	5/8" x 9"	1.80"	0.88"	3,500	3.00
9EE625X12	5/8" x 12"	1.80"	0.88"	3,500	3.25
9EE750X06	3/4" x 6"	2.09"	1.00"	5,200	3.75
9EE750X09	3/4" x 9"	2.09"	1.00"	5,200	4.50
9EE750X12	3/4" x 12"	2.09"	1.00"	5,200	5.75
9EE750X18	3/4" x 18"	2.09"	1.00"	5,200	7.00
9EE875X12	7/8" x 12"	2.38"	1.25"	7,200	8.38
9EE875X18	7/8" x 18"	2.38"	1.25"	7,200	10.25
9EE100X12	1" x 12"	3.00"	1.43"	10,000	12.00



9EE750X06



NOTE: Maximum load ratings are based on a straight vertical pull in a gradually increasing manner. Any deviations such as angular lifts, shock loads, modification of the basic part, etc., will result in drastically reduced maximum loads. Turnbuckles are recommended for straight or in-line pull only.



EYE/JAW TURNBUCKLES - DROP FORGED, HOT GALVANIZED

Part #	Size x Take Up	Eye Dim (A)	Eye Dim (B)	Jaw Dim (C)	Jaw Dim (D)	WLL (Lbs)	Wt (Lbs)/Ea
9EJ250X04	1/4" x 4"	0.81"	0.34"	0.45"	0.64"	500	0.30
9EJ312X04	5/16" x 4-1/2"	0.95"	0.44"	0.50"	0.87"	800	0.55
9EJ375X06	3/8" x 6"	1.13"	0.53"	0.53"	0.87"	1,200	0.90
9EJ500X06	1/2" x 6"	1.41"	0.71"	0.64"	1.07"	2,200	1.50
9EJ500X09	1/2" x 9"	1.41"	0.71"	0.64"	1.07"	2,200	2.00
9EJ500X12	1/2" x 12"	1.41"	0.71"	0.64"	1.07"	2,200	2.20
9EJ625X06	5/8" x 6"	1.80"	0.88"	0.79"	1.32"	3,500	2.63
9EJ625X09	5/8" x 9"	1.80"	0.88"	0.79"	1.32"	3,500	3.00
9EJ625X12	5/8" x 12"	1.80"	0.88"	0.79"	1.32"	3,500	3.25
9EJ750X06	3/4" x 6"	2.09"	1.00"	0.97"	1.52"	5,200	3.75
9EJ750X09	3/4" x 9"	2.09"	1.00"	0.97"	1.52"	5,200	4.50
9EJ750X12	3/4" x 12"	2.09"	1.00"	0.97"	1.52"	5,200	5.75
9EJ750X18	3/4" x 18"	2.09"	1.00"	0.97"	1.52"	5,200	7.00
9EJ875X12	7/8" x 12"	2.38"	1.25"	1.16"	1.75"	7,200	8.38
9EJ875X18	7/8" x 18"	2.38"	1.25"	1.16"	1.75"	7,200	10.25
9EJ100X12	1" x 12"	3.00"	1.43"	1.34"	2.05"	10,000	12.00



3/4" and larger are supplied with pin and cotter pin.



9EE250X04



JAW/JAW TURNBUCKLES - DROP FORGED, HOT GALVANIZED

Part #	Size x Take Up	Jaw Dim (A)	Jaw Dim (B)	WLL (Lbs)	Wt (Lbs)/Ea
9JJ250X04	1/4" x 4"	0.45"	0.64"	500	0.30
9JJ312X04	5/16" x 4-1/2"	0.50"	0.87"	800	0.55
9JJ375X06	3/8" x 6"	0.53"	0.87"	1,200	0.90
9JJ500X06	1/2" x 6"	0.64"	1.07"	2,200	1.50
9JJ500X09	1/2" x 9"	0.64"	1.07"	2,200	2.00
9JJ500X12	1/2" x 12"	0.64"	1.07"	2,200	2.20
9JJ625X06	5/8" x 6"	0.79"	1.32"	3,500	2.63
9JJ625X09	5/8" x 9"	0.79"	1.32"	3,500	3.00
9JJ625X12	5/8" x 12"	0.79"	1.32"	3,500	3.25
9JJ750X06	3/4" x 6"	0.97"	1.52"	5,200	3.75
9JJ750X09	3/4" x 9"	0.97"	1.52"	5,200	4.50
9JJ750X12	3/4" x 12"	0.97"	1.52"	5,200	5.75
9JJ750X18	3/4" x 18"	0.97"	1.52"	5,200	7.00
9JJ875X12	7/8" x 12"	0.88"	1.75"	7,200	8.38
9JJ875X18	7/8" x 18"	0.88"	1.75"	7,200	10.25
9JJ100X12	1" x 12"	1.34"	2.05"	10,000	12.00



3/4" and larger are supplied with pin and cotter pin.



9JJ250X04



EYE/HOOK TURNBUCKLES - DROP FORGED, HOT GALVANIZED



9EH375X06

Part #	Size x Take Up	Eye Dim (A)	Eye Dim (B)	Hook Dim (C)	Hook Dim (D)	WLL (Lbs)	Wt (Lbs)/Ea
9EH250X04	1/4" x 4"	0.81"	0.34"	0.44"	1.27"	400	0.30
9EH312X04	5/16" x 4-1/2"	0.95"	0.44"	0.50"	1.50"	700	0.55
9EH375X06	3/8" x 6"	1.13"	0.53"	0.56"	1.75"	1,000	0.90
9EH500X06	1/2" x 6"	1.41"	0.71"	0.65"	2.28"	1,500	1.50
9EH500X09	1/2" x 9"	1.41"	0.71"	0.65"	2.28"	1,500	2.00
9EH500X12	1/2" x 12"	1.41"	0.71"	0.65"	2.28"	1,500	2.20
9EH625X06	5/8" x 6"	1.80"	0.88"	0.90"	2.81"	2,250	2.63
9EH625X09	5/8" x 9"	1.80"	0.88"	0.90"	2.81"	2,250	3.00
9EH625X12	5/8" x 12"	1.80"	0.88"	0.90"	2.81"	2,250	3.25
9EH750X06	3/4" x 6"	2.09"	1.00"	0.98"	3.33"	3,000	3.75
9EH750X09	3/4" x 9"	2.09"	1.00"	0.98"	3.33"	3,000	4.50
9EH750X12	3/4" x 12"	2.09"	1.00"	0.98"	3.33"	3,000	5.75
9EH750X18	3/4" x 18"	2.09"	1.00"	0.98"	3.33"	3,000	7.00
9EH875X12	7/8" x 12"	2.38"	1.25"	1.13"	3.78"	4,000	8.38
9EH875X18	7/8" x 18"	2.38"	1.25"	1.13"	3.78"	4,000	10.25
9EH100X12	1" x 12"	3.00"	3.00"	1.25"	4.25"	5,000	12.00



HOOK/HOOK TURNBUCKLES - DROP FORGED, HOT GALVANIZED

Part #	Size x Take Up	Hook Dim (A)	Hook Dim (B)	WLL (Lbs)	Wt (Lbs)/Ea
9HH250X04	1/4" x 4"	0.44"	1.27"	400	0.30
9HH312X04	5/16" x 4-1/2"	0.50"	1.50"	700	0.55
9HH375X06	3/8" x 6"	0.56"	1.75"	1,000	0.90
9HH500X06	1/2" x 6"	0.65"	2.28"	1,500	1.50
9HH500X09	1/2" x 9"	0.65"	2.28"	1,500	2.00
9HH500X12	1/2" x 12"	0.65"	2.28"	1,500	2.20
9HH625X06	5/8" x 6"	0.90"	2.81"	2,250	2.63
9HH625X09	5/8" x 9"	0.90"	2.81"	2,250	3.00
9HH625X12	5/8" x 12"	0.90"	2.81"	2,250	3.25
9HH750X06	3/4" x 6"	0.98"	3.33"	3,000	3.75
9HH750X09	3/4" x 9"	0.98"	3.33"	3,000	4.50
9HH750X12	3/4" x 12"	0.98"	3.33"	3,000	5.75
9HH750X18	3/4" x 18"	0.98"	3.33"	3,000	7.00
9HH875X12	7/8" x 12"	1.13"	3.78"	4,000	8.38
9HH875X18	7/8" x 18"	1.13"	3.78"	4,000	10.25
9HH100X12	1" x 12"	1.25"	4.25"	5,000	12.00



9HH312X04



EYE/EYE STAINLESS STEEL TURNBUCKLES - PRECISION CAST, TYPE 316

Part #	Size x Take Up	WLL (Lbs)	Wt (Lbs)/Ea
S9EE250X04	1/4" x 3"	440	0.20
S9EE375X06	3/8" x 6"	1,260	0.80
S9EE500X06	1/2" x 6"	1,650	1.25
S9EE625X06	5/8" x 6"	2,000	3.05
S9EE750X06	3/4" x 6"	3,000	4.25



S9EE250X04



JAW/JAW STAINLESS STEEL TURNBUCKLES - PRECISION CAST, TYPE 316

Part #	Size x Take Up	WLL (Lbs)	Wt (Lbs)/Ea
S9JJ250X04	1/4" x 4"	460	0.40
S9JJ375X06	3/8" x 6"	1,300	1.25
S9JJ500X06	1/2" x 6"	1,800	1.50
S9JJ625X06	5/8" x 6"	2,100	3.10
S9JJ750X06	3/4" x 6"	3,000	4.25



S9JJ375X06



STUB END TURNBUCKLES - SELF COLORED, CARBON STEEL

Part #	Size x Take Up	WLL (Lbs)	Wt (Lbs)/Ea
9SS375X06	3/8" x 6"	1,200	1.00
9SS500X06	1/2" x 6"	2,200	1.00
9SS625X06	5/8" x 6"	3,500	2.30
9SS750X06	3/4" x 6"	5,200	3.00
9SS875X06	7/8" x 6"	7,200	5.00
9SS100X06	1" x 6"	10,000	6.40



9SS375X06



QUICK LINKS - ZINC PLATED

Part #	Size	WLL (Lbs)	Max. Opening	Pcs/Pack	Wt (Lbs)/Pack
QL125-DP	1/8"	220	0.21"	50	1.25
QL187-DP	3/16"	660	0.24"	50	2.25
QL187-WIDE	3/16"	660	0.44"	1	0.04
QL250-DP	1/4"	880	0.29"	50	3.50
QL250-WIDE	1/4"	880	0.48"	1	0.10
QL312-DP	5/16"	1,600	0.42"	50	9.00
QL375-DP	3/8"	2,200	0.50"	10	3.20
QL500-DP	1/2"	3,300	0.51"	10	6.00
QL625	5/8"	4,000	0.80"	1	1.30



QL187-DP



WIDE JAW
QL187-WIDE



QUICK LINKS - STAINLESS STEEL

Part #	Size	Material	WLL (Lbs)	Max. Opening	Pcs/Pack	Wt (Lbs)/Pack
SQL125-T316	1/8"	T-316	220	0.17"	1	0.02
SQL187-T316	3/16"	T-316	660	0.26"	1	0.05
SQL250-T316	1/4"	T-316	880	0.32"	1	0.09
SQL312-T316	5/16"	T-316	1,600	0.44"	1	0.19
SQL375-T316	3/8"	T-316	2,200	0.52"	1	0.30
SQL500-T316	1/2"	T-316	3,300	0.57"	1	0.53



SQL250-T316



FORGED CARBON PEAR LINKS*

Part #	Size	Finish	WLL (lbs)	Wt/Ea
PL375 (Carbon Steel)	3/8"	Painted Black	1,800	0.23
PL500YZ	1/2"	Yellow Zinc Plated	7,000	1.00
PL625YZ	5/8"	Yellow Zinc Plated	9,000	1.20
PL750YZ	3/4"	Yellow Zinc Plated	12,300	1.40



PL750YZ



- Rated for overhead lifting applications.
- Do not exceed the rated working load limit.
- WLL based on single leg sling (in line loads).
- Inspect and replace if worn, distorted or damaged.



SWIVELS - DROP FORGED, HOT GALVANIZED

Part #	Style	Size	WLL (Lbs)	Wt/Ea
DFSWIV250EJ	Eye/Jaw	1/4"	800	0.30
DFSWIV250EE	Eye/Eye	1/4"	800	0.20
DFSWIV312EJ	Eye/Jaw	5/16"	1,200	0.34
DFSWIV312EE	Eye/Eye	5/16"	1,200	0.37
DFSWIV375EJ	Eye/Jaw	3/8"	2,200	0.70
DFSWIV375EE	Eye/Eye	3/8"	2,200	0.70
DFSWIV500EJ	Eye/Jaw	1/2"	3,500	1.40
DFSWIV500EE	Eye/Eye	1/2"	3,500	1.40
DFSWIV625EJ	Eye/Jaw	5/8"	5,200	2.20
DFSWIV625EE	Eye/Eye	5/8"	5,200	2.20



EYE/JAW
DFSWIV625EJ



EYE/EYE
DFSWIV500EE



SWIVELS - STAINLESS STEEL, TYPE 304

Part #	Style	Size	Trade Size	WLL (Lbs)	Wt/Ea
SSWIV06EJ	Eye/Jaw	6 mm	1/4"	600	0.09
SSWIV06EE	Eye/Eye	6 mm	1/4"	600	0.09
SSWIV06JJ	Jaw/Jaw	6 mm	1/4"	600	0.09
SSWIV08EJ	Eye/Jaw	8 mm	5/16"	1,050	0.33
SSWIV08EE	Eye/Eye	8 mm	5/16"	1,050	0.33
SSWIV08JJ	Jaw/Jaw	8 mm	5/16"	1,050	0.33
SSWIV10EJ	Eye/Jaw	10 mm	3/8"	1,930	0.65
SSWIV10EE	Eye/Eye	10 mm	3/8"	1,930	0.65
SSWIV10JJ	Jaw/Jaw	10 mm	3/8"	1,930	0.65
SSWIV13EJ	Eye/Jaw	13 mm	1/2"	2,750	1.50
SSWIV13EE	Eye/Eye	13 mm	1/2"	2,750	1.50
SSWIV13JJ	Jaw/Jaw	13 mm	1/2"	2,750	1.50
SSWIV16EJ	Eye/Jaw	16 mm	5/8"	4,680	2.66
SSWIV16EE	Eye/Eye	16 mm	5/8"	4,680	2.66
SSWIV16JJ	Jaw/Jaw	16 mm	5/8"	4,680	2.66



EYE/JAW
SSWIV06EJ



EYE/EYE
SSWIV10EE



JAW/JAW
SSWIV08JJ





COLD SHUTS - ZINC PLATED

Part #	Size	Width	Length	Pcs/Pack	Wt (Lbs)/Pack
CSHUT187-DP	3/16"	11/32"	15/16"	100	3
CSHUT250-DP	1/4"	3/8"	1-3/16"	100	6
CSHUT312-DP	5/16"	7/16"	1-3/8"	100	12
CSHUT375-DP	3/8"	5/8"	1-1/2"	100	17
CSHUT500-DP	1/2"	3/4"	1-7/8"	25	10
CSHUT625-DP	5/8"	13/16"	2"	25	21

Used to link to or repair steel chains.



CSHUT187-DP



CONNECTING LINKS - ZINC PLATED

Part #	Size	WLL (Lbs)	Pcs/Pack	Wt (Lbs)/Pack
CLINK187-DP	3/16"	750	10	0.30
CLINK250-DP	1/4"	1,250	10	0.60
CLINK312-DP	5/16"	1,900	10	1.30
CLINK375-DP	3/8"	2,650	10	2.15
CLINK500-DP	1/2"	4,500	10	3.60
CLINK625	5/8"	6,950	1	0.75

Primarily used to connect two chains or a chain to an end component.

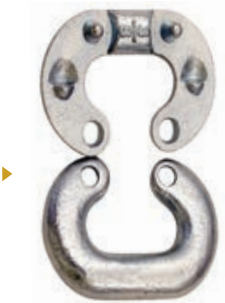

CLINK375-DP



LAP LINKS - ZINC PLATED

Part #	Size	WLL (Lbs)	Pcs/Pack	Wt (Lbs)/Pack
LL125-DP	1/8" x 3/4"	150	100	1.20
LL187-DP	3/16" x 1"	225	100	4.00
LL250-DP	1/4" x 1-1/4"	325	100	8.00
LL312-DP	5/16" x 1-1/2"	675	100	14.00
LL375-DP	3/8" x 1-5/8"	1,050	50	12.50
LL500-DP	1/2" x 2-1/2"	1,525	50	28.00

Used to temporarily repair steel chains and add coupling attachments.



LL250-DP

**DOUBLE CLEVIS - ZINC PLATED**

Part #	Size	WLL (Lbs)	Wt (Lbs)/Ea
DC250-312	1/4"- 5/16"	3,900	0.31
DC375	3/8"	5,400	0.70
DC500	1/2"	9,200	1.56
DC625	5/8"	13,000	2.09

Forged carbon steel body and alloy pin.



DC375

**S-HOOKS - ZINC PLATED**

Part #	Size	Pcs/Pack	Wt (Lbs)/Pack
EGSH125	1/8" x 1"	100	1.00
EGSH187	3/16" x 1-1/2"	100	3.00
EGSH250	1/4" x 2-1/4"	100	6.50
EGSH406	13/32" x 2-7/8"	50	15.00



EGSH250



EGSH406

**S-HOOKS - STAINLESS STEEL**

Part #	Size	Wt (Lbs)/Pack
SSSH250	1/4"	0.06
SSSH312	5/16"	0.12



SSSH250

**STAPLES - HOT GALVANIZED**

Part #	Size	Wt (Lbs)/Ea
STAPLE375	3/8" x 4-1/2"	0.25
STAPLE500	1/2" x 6"	0.55
STAPLE500-8	1/2" x 8"	0.65



STAPLE500

**SPLIT RINGS - ZINC PLATED**

Part #	Outside Diameter	Inside Diameer	Wt (Lbs)/Ea
SPLITRING1750	1-3/4"	1-5/16"	0.044

Spread ring for easy installation.



SPLITRING1750



SNAP HOOKS - NICKEL PLATED

Part #	Size	Pcs/Pack	Wt (Lbs)/Pack
SNAP161	3/8" x 3-1/4"	50	4
SNAP163	1/2" x 4-3/4"	50	8
SNAP225-625	5/8" x 3-1/2"	100	14
SNAP225-750	3/4" x 3-1/2"	100	15
*SNAP230	3/8" x 3-1/4"	100	9
SNAP232	1/2" x 4"	100	16



SNAP163



* Zinc Plated



SNAP225-750



*SNAP230
ZINC PLATED



#2450 SPRING HOOKS - BLACK COATED

Part #	Description	Size	Wt (Lbs)/Ea
SNAP2450-250NE-BLK	Without Eye	1/4"	0.06
SNAP2450-250WE-BLK	With Eye	1/4"	0.07
SNAP2450-312NE-BLK	Without Eye	5/16"	0.14
SNAP2450-312WE-BLK	With Eye	5/16"	0.15



SNAP2450-250NE-BLK
WITHOUT EYE



Gary



SNAP2450-250WE-BLK
WITH EYE





#2450 SPRING HOOKS - ZINC PLATED

Part #	Description	Size	Wt (Lbs)/Ea
SNAP2450-187NE	Without Eye	3/16"	0.04
SNAP2450-250NE	Without Eye	1/4"	0.06
SNAP2450-250WE	With Eye	1/4"	0.07
SNAP2450-281NE	Without Eye	9/32"	0.09
SNAP2450-312NE	Without Eye	5/16"	0.14
SNAP2450-312WE	With Eye	5/16"	0.15
SNAP2450-344NE	Without Eye	11/32"	0.21
SNAP2450-375NE	Without Eye	3/8"	0.29
SNAP2450-437NE	Without Eye	7/16"	0.40
SNAP2450-500NE	Without Eye	1/2"	0.80



SSNAP2450-187NE
WITHOUT EYE



SNAP2450-250WE
WITH EYE



#2450 STAINLESS STEEL SPRING HOOKS - TYPE 304

Part #	Description	Size	Wt (Lbs)/Ea
SSNAP2450-187	Without Eye	3/16"	0.04
SSNAP2450-250	Without Eye	1/4"	0.07
SSNAP2450-281	Without Eye	9/32"	0.09
SSNAP2450-312	Without Eye	5/16"	0.16
SSNAP2450-375	Without Eye	3/8"	0.29
SSNAP2450-437	Without Eye	7/16"	0.40
SSNAP2450-500	Without Eye	1/2"	0.80



SSNAP2450-312





CLEVIS SLIP HOOKS - HIGH TEST

Part #	Size	Finish	WLL (Lbs)	Wt (Lbs)/Ea
EGHTSH250	1/4"	EG	1,950	0.40
EGHTSH312	5/16"	EG	2,875	0.78
EGHTSH375	3/8"	EG	4,000	1.00
EGHTSH500	1/2"	EG	6,500	2.44



EGHTSH375



CLEVIS SLIP HOOKS - HIGH TEST WITH SAFETY LATCH

Part #	Size	Finish	WLL (Lbs)	Wt (Lbs)/Ea
HTSH250-WL	1/4"	EG	1,950	0.55
HTSH312-WL	5/16"	EG	2,875	0.83
HTSH375-WL	3/8"	EG	4,000	1.21
HTSH500-WL	1/2"	EG	6,500	2.78



HTSH375



CLEVIS SLIP HOOKS - GRADE 70 TRANSPORT

Part #	Size	Finish	WLL (Lbs)	Wt (Lbs)/Ea
G7CS250	1/4"	Yellow Zinc	2,750	0.47
G7CS312	5/16"	Yellow Zinc	4,300	0.75
G7CS375	3/8"	Yellow Zinc	5,250	1.30
G7CS375-WL (w/latch)	3/8"	Yellow Zinc	5,250	1.60
G7CS500	1/2"	Yellow Zinc	9,000	2.73



G7CS375



EYE SLIP HOOKS - HIGH TEST

Part #	Size	Finish	WLL (Lbs)	Wt (Lbs)/Ea
EGHTES250	1/4"	EG	1,950	0.50
EGHTES312	5/16"	EG	2,875	0.69
EGHTES375	3/8"	EG	4,000	1.00
EGHTES500	1/2"	EG	6,500	2.40



EGHTES312



EYE GRAB HOOKS - HIGH TEST

Part #	Size	Finish	WLL (Lbs)	Wt (Lbs)/Ea
EGHTEG250	1/4"	EG	2,600	0.35
EGHTEG312	5/16"	EG	3,900	0.53
EGHTEG375	3/8"	EG	5,400	0.94



EGHTEG312



CLEVIS GRAB HOOKS - HIGH TEST

Part #	Size	Finish	WLL (Lbs)	Wt (Lbs)/Ea
EGHTGH250	1/4"	EG	2,600	0.40
EGHTGH312	5/16"	EG	3,900	0.78
EGHTGH375	3/8"	EG	5,400	1.00
EGHTGH437	7/16"	EG	7,200	1.70
EGHTGH500	1/2"	EG	9,200	2.45
EGHTGH625	5/8"	EG	12,750	6.00



EGHTGH250



Mark



Owen



CLEVIS GRAB HOOKS - GRADE 70 TRANSPORT

Part #	Size	Finish	WLL (Lbs)	Wt (Lbs)/Ea
G7CG312	5/16"	Yellow Zinc	4,700	0.70
G7CG375	3/8"	Yellow Zinc	6,600	1.19
G7CG500	1/2"	Yellow Zinc	11,300	2.33



G7CG312



CLEVIS GRAB HOOKS - GRADE 80 ALLOY

Part #	Size	Finish	WLL (Lbs)	Wt (Lbs)/Ea
G8CG250	1/4"	Painted	3,500	0.46
G8CG312	5/16"	Painted	5,100	0.75
G8CG375	3/8"	Painted	7,100	1.18
G8CG500	1/2"	Painted	12,000	2.40
G8CG625	5/8"	Painted	18,100	4.40



G8CG375



EYE HOIST HOOKS - ALLOY WITH SAFETY LATCH

Part #	Size	Finish	WLL (Tons)	Wt (Lbs)/Ea
HH1TA	1.0 Ton	Yellow Zinc	1.0	0.53
HH1.5A	1.5 Ton	Yellow Zinc	1.5	0.88
HH2TA	2.0 Ton	Yellow Zinc	2.0	1.20
HH3TA	3.0 Ton	Yellow Zinc	3.0	2.00
HH7TA	7.0 Ton	Yellow Zinc	7.0	7.10



HH2TA



FEHR FORGED SHACKLES MEET THE PERFORMANCE REQUIREMENTS OF APPLICABLE FEDERAL SPECIFICATION RR-C-271, AND HAVE A MINIMUM SAFETY DESIGN FACTOR OF 5 : 1.



DUTY RATED SCREW PIN ANCHOR SHACKLES - HOT GALVANIZED

Part #	Size (A)	Pin Diameter (B)	Throat Opening (C)	Inside Length (D)	WLL (Tons)	Pcs/Pack	Wt (Lbs)/Ea
DRSPA187	3/16"	0.25"	0.34"	0.84"	1/3	25	0.07
DRSPA250	1/4"	0.312"	0.54"	1.11"	1/2	25	0.11
DRSPA312	5/16"	0.375"	0.57"	1.15"	3/4	25	0.18
DRSPA375	3/8"	0.437"	0.67"	1.45"	1	25	0.32
DRSPA437	7/16"	0.50"	0.718"	1.65"	1-1/2	10	0.48
DRSPA500	1/2"	0.625"	0.84"	1.90"	2	10	0.68
DRSPA625	5/8"	0.75"	1.13"	2.38"	3-1/4	10	1.46
DRSPA750	3/4"	0.875"	1.25"	2.75"	4-3/4	5	2.34
DRSPA875	7/8"	1.00"	1.54"	3.50"	6-1/2	5	3.78
DRSPA100	1"	1.125"	1.65"	3.75"	8-1/2	5	5.00
DRSPA1.125	1-1/8"	1.25"	1.74"	4.13"	9-1/2	1	7.00
DRSPA1.25	1-1/4"	1.375"	2.00"	4.75"	12	1	10.25
DRSPA1.375	1-3/8"	1.50"	2.17"	5.13"	13-1/2	1	13.30
DRSPA1.50	1-1/2"	1.625"	2.45"	5.75"	17	1	16.80
DRSPA1.75	1-3/4"	2.00"	2.88"	7.00"	25	1	28.10
DRSPA200	2"	2.25"	3.25"	7.50"	35	1	40.10

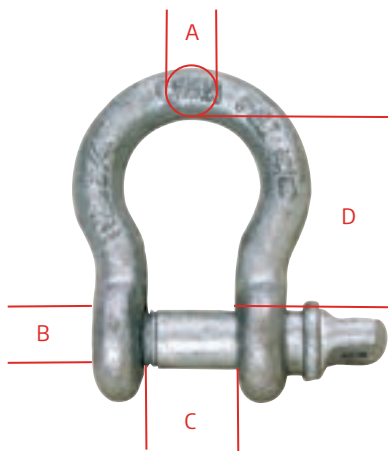

DRSPA625





DUTY RATED SCREW PIN ANCHOR SHACKLES - BLACK MADE IN USA

Part #	Size (A)	Pin Diameter (B)	Throat Opening (C)	Inside Length (D)	WLL (Tons)	Wt (Lbs)/Ea
THSPA250BL	1/4"	0.312"	0.45"	1.12"	1/2	0.13
THSPA312BL	5/16"	0.375"	0.50"	1.23"	3/4	0.18
THSPA375BL	3/8"	0.437"	0.70"	1.40"	1	0.33
THSPA500BL	1/2"	0.625"	0.84"	1.92"	2	0.74
THSPA625BL	5/8"	0.75"	1.12"	2.45"	3-1/4	1.30
THSPA750BL	3/4"	0.875"	1.25"	2.84"	4-3/4	2.14

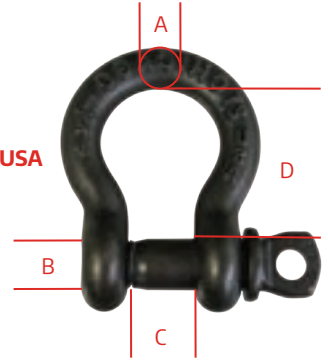

THSPA500BL



SCREW PIN CHAIN SHACKLES - HOT GALVANIZED

Part #	Size (A)	Pin Diameter (B)	Throat Opening (C)	Inside Length (D)	WLL (Tons)	Wt (Lbs)/Ea
DRSPC375	3/8"	0.44"	0.66"	1.28"	1	0.30
DRSPC500	1/2"	0.63"	0.81"	1.66"	2	0.65
DRSPC625	5/8"	0.75"	1.06"	2.04"	3-1/4	1.30
DRSPC750	3/4"	0.88"	1.25"	2.40"	4-3/4	2.63
DRSPC875	7/8"	1.00"	1.44"	2.86"	6-1/2	3.37
DRSPC100	1"	1.13"	1.69"	3.25"	8-1/2	4.90

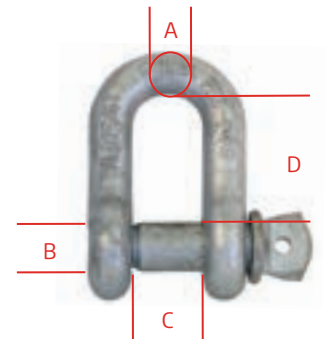

DRSPC375



Dave





SAFETY SHACKLES WITH NUT & PIN - HOT GALVANIZED

Part #	Size (A)	Pin Diameter (B)	Throat Opening (C)	Inside Length (D)	WLL (Tons)	Wt (Lbs)/Ea
DRSAF500	1/2"	0.625"	0.815"	1.82"	2	0.75
DRSAF625	5/8"	0.75"	1.00"	2.35"	3-1/4	1.30
DRSAF750	3/4"	0.875"	1.34"	2.80"	4-3/4	2.20
DRSAF875	7/8"	1.00"	1.50"	3.35"	6-1/2	3.60
DRSAF100	1"	1.125"	1.75"	3.70"	8-1/2	5.60

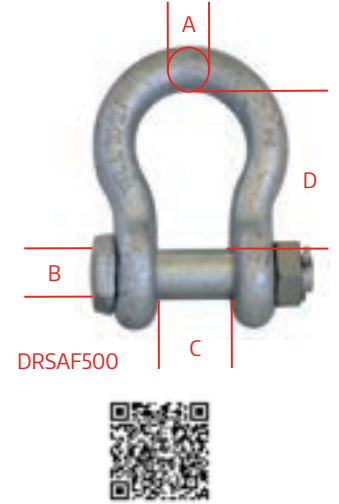

FEDERAL SPECIFICATION RR-C-271 IS NOT APPLICABLE TO COMMERCIAL GRADE AND STAINLESS STEEL SHACKLES.



COMMERCIAL GRADE SCREW PIN ANCHOR SHACKLES - HOT GALVANIZED

Part #	Size (A)	Pin Diameter (B)	Throat Opening (C)	Inside Length (D)	WLL (Tons)	Pcs/Pack	Wt (Lbs)/Ea
CGSPA187	3/16"	0.25"	0.42"	0.90"	1/4	25	0.05
CGSPA250	1/4"	0.312"	0.525"	1.04"	1/3	25	0.09
CGSPA312	5/16"	0.375"	0.59"	1.28"	1/2	25	0.17
CGSPA375	3/8"	0.437"	0.675"	1.58"	3/4	25	0.30
CGSPA437	7/16"	0.50"	0.895"	1.83"	1	25	0.40
CGSPA500	1/2"	0.625"	1.05"	2.00"	1-1/2	25	0.69
CGSPA625	5/8"	0.75"	1.25"	2.45"	2-1/4	25	1.39
CGSPA750	3/4"	0.875"	1.35"	2.92"	3-1/4	5	1.70
CGSPA875	7/8"	1.00"	1.68"	3.30"	4-1/4	1	2.80
CGSPA100	1"	1.125"	1.71"	3.75"	5-1/2	1	4.90

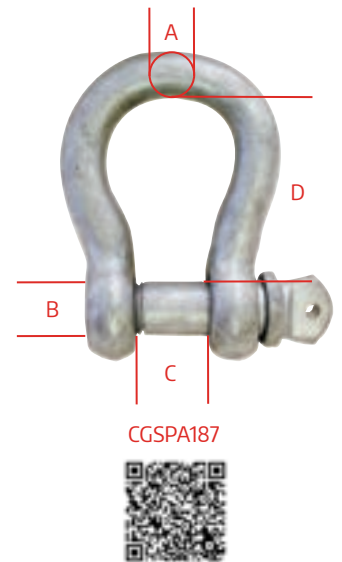



STAINLESS STEEL SCREW PIN BOW SHACKLES - TYPE 316

Part #	Size (A)	Pin Diameter (B)	Throat Opening (C)	Inside Length (D)	WLL (Lbs)	Wt (Lbs)/Ea
SSPA187	3/16"	0.187"	0.40"	1.00"	660	0.04
SSPA250	1/4"	0.25"	0.50"	1.20"	930	0.06
SSPA312	5/16"	0.312"	0.70"	1.45"	1,375	0.16
SSPA375	3/8"	0.375"	0.84"	1.83"	2,365	0.31
SSPA500	1/2"	0.50"	1.00"	2.30"	3,400	0.66
SSPA625	5/8"	0.625"	1.26"	2.85"	5,500	1.44
SSPA750	3/4"	0.75"	1.50"	3.34"	7,700	2.25
SSPA875	7/8"	0.875"	1.75"	3.70"	8,000	2.90
SSPA100	1"	1.00"	2.00"	4.16"	10,000	4.67
SSPA1.125	1-1/8"	1.125"	2.05"	4.63"	12,000	6.00

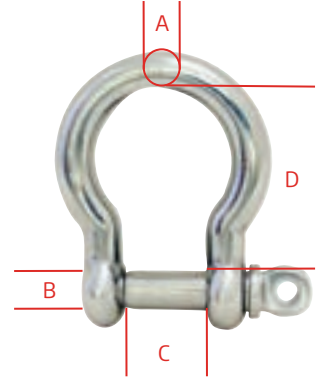

SSPA500



STAINLESS STEEL WIDE D SHACKLES - TYPE 316

Part #	Size (A)	Pin Diameter (B)	Throat Opening (C)	Inside Length (D)	Minimum Working Load (Lbs)	Wt (Lbs)/Ea
SSDS250	1/4"	0.250"	0.92"	1.30"	750	0.08
SSDS312	5/16"	0.312"	1.10"	1.22"	1,000	0.14
SSDS375	3/8"	0.375"	1.54"	2.15"	1,200	0.34
SSDS500	1/2"	0.500"	1.80"	2.60"	1,500	0.60

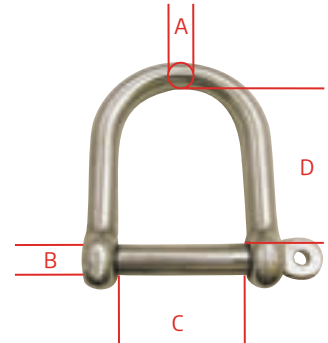

SSDS312



STAINLESS STEEL STRAIGHT D SHACKLES - TYPE 316

Part #	Size (A)	Pin Diameter (B)	Throat Opening (C)	Inside Length (D)	WLL (Lbs)	Wt (Lbs)/Ea
SSSD156	5/32"	0.156"	0.34"	0.55"	200	0.02
SSSD250	1/4"	0.25"	0.50"	0.864"	750	0.06
SSSD312	5/16"	0.312"	0.671"	1.15"	1,000	0.14

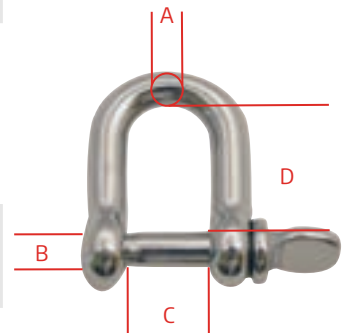

SSSD312



FEHR EYEBOLTS HAVE A MINIMUM SAFETY DESIGN FACTOR OF 5 : 1.



EYEBOLTS - DROP FORGED, HOT GALVANIZED, XL THREAD

Part #	Size x Shank Length	Eye Diameter (A)	Thread Length (B)	WLL (Lbs)	Wt (Lbs)/Ea
EB250X02	1/4" x 2"	0.50"	1.00"	650	0.07
EB250X04	1/4" x 4"	0.50"	2.00"	650	0.10
EB312X02	5/16" x 2"	0.625"	1.00"	1,200	0.13
EB312X04	5/16" x 4-1/4"	0.625"	2.00"	1,200	0.15
EB375X02	3/8" x 2-1/2"	0.75"	1.25"	1,550	0.20
EB375X04	3/8" x 4-1/2"	0.75"	2.25"	1,550	0.25
EB375X06	3/8" x 6"	0.75"	3.00"	1,550	0.30
EB500X03	1/2" x 3-1/4"	1.00"	1.50"	2,600	0.50
EB500X06	1/2" x 6"	1.00"	3.00"	2,600	0.60
EB500X08	1/2" x 8"	1.00"	4.00"	2,600	0.76
EB500X10	1/2" x 10"	1.00"	5.00"	2,600	0.88
EB500X12	1/2" x 12"	1.00"	6.00"	2,600	0.94
EB500X18	1/2" x 18"	1.00"	9.00"	2,600	1.25
EB625X04	5/8" x 4"	1.25"	2.00"	4,750	0.95
EB625X06	5/8" x 6"	1.25"	3.00"	4,750	1.09
EB625X08	5/8" x 8"	1.25"	4.00"	4,750	1.20
EB625X10	5/8" x 10"	1.25"	5.00"	4,750	1.40
EB625X12	5/8" x 12"	1.25"	6.00"	4,750	1.55
EB625X15	5/8" x 15"	1.25"	7.50"	4,750	1.68
EB625X18	5/8" x 18"	1.25"	9.00"	4,750	2.00
EB625X21	5/8" x 21"	1.25"	10.50"	4,750	2.35
EB625X24	5/8" x 24"	1.25"	12.00"	4,750	2.45
EB750X04	3/4" x 4-1/2"	1.50"	2.25"	6,450	1.40
EB750X06	3/4" x 6"	1.50"	3.00"	6,450	1.75
EB750X08	3/4" x 8"	1.50"	4.00"	6,450	2.00
EB750X10	3/4" x 10"	1.50"	5.00"	6,450	2.20
EB750X12	3/4" x 12"	1.50"	6.00"	6,450	2.30
EB875X05	7/8" x 5"	1.75"	2.50"	9,500	2.58
EB875X08	7/8" x 8"	1.75"	4.00"	9,500	2.75





SHOULDER MACHINERY EYEBOLTS - DROP FORGED, SELF COLORED

Part #	Size x Shank Length	Eye Diameter (A)	Thread Length (B)	WLL (Lbs)	Wt (Lbs)/Ea
SMEB250X1.000	1/4" x 1"	0.75"	1.000"	500	0.06
SMEB312X1.125	5/16" x 1-1/8"	0.875"	1.125"	900	0.10
SMEB375X1.250	3/8" x 1-1/4"	1.00"	1.250"	1,300	0.17
SMEB437X1.375	7/16" x 1-3/8"	1.093"	1.375"	1,800	0.26
SMEB500X1.500	1/2" x 1-1/2"	1.187"	1.500"	2,400	0.36
SMEB625X1.750	5/8" x 1-3/4"	1.375"	1.750"	4,000	0.57
SMEB750X2.000	3/4" x 2"	1.50"	2.000"	5,000	1.05
SMEB875X2.250	7/8" x 2-1/4"	1.75"	2.250"	7,000	1.87
SMEB100X2.500	1" x 2-1/2"	1.875"	2.500"	9,000	2.36



SMEB500X1.500



PLAIN MACHINERY EYEBOLTS - DROP FORGED, SELF COLORED

Part #	Size x Shank Length	Eye Diameter (A)	Thread Length (B)	WLL (Lbs)	Wt (Lbs)/Ea
PMEB250X1.000	1/4" x 1"	0.75"	1.000"	500	0.04
PMEB312X1.125	5/16" x 1-1/8"	0.875"	1.125"	900	0.09
PMEB375X1.250	3/8" x 1-1/4"	1.00"	1.250"	1,300	0.15
PMEB500X1.500	1/2" x 1-1/2"	1.187"	1.500"	2,400	0.36
PMEB625X1.750	5/8" x 1-3/4"	1.375"	1.750"	4,000	0.60
PMEB750X2.000	3/4" x 2"	1.50"	2.000"	5,000	0.94
PMEB100X2.500	1" x 2-1/2"	1.875"	2.500"	9,000	2.31

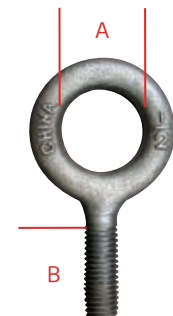

PMEB500X1.500



METRIC SHOULDER MACHINERY EYEBOLTS **MADE IN USA**

Part #	Nominal Size x Shank Length	Eye Diameter (A)	Thread Length (B)	WLL (Lbs)	Wt (Lbs)/Ea
SMEB8	8 mm x 32 mm	1.00"	1.25"	1,100	0.20
SMEB10	10 mm x 38 mm	1.00"	1.375"	1,630	0.24



SMEB10





EYEBOLT WASHERS - HOT GALVANIZED

Part #	Outside Dimension	Inside Dimension	Thickness	Wt (Lbs)/Ea
WASHER500	1.39"	0.55"	0.097"	0.034
WASHER625	1.78"	0.70"	0.140"	0.08



WASHER500



EYE LAG SCREWS - DROP FORGED, HOT GALVANIZED

Part #	Size x Shank Length	Eye Diameter (A)	Thread Length (B)	WLL (Lbs)	Wt (Lbs)/Ea
ES500X3.25	1/2" x 3-1/4"	1.00"	3.25"	1,900	0.45
ES625X4	5/8" x 4"	1.25"	4.00"	3,100	0.75



B

ES500X3.25



LAGHOOK250

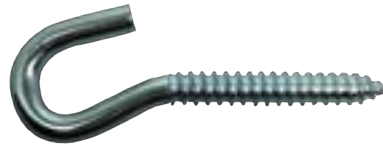

OPENLAG250SS



OPEN LAG HOOK

Part #	Size x Shank Length	Finish	Wt (Lbs)/Ea
LAGHOOK250	3/16" x 3-3/4"	Zinc Plated	0.05
SLAGHOOK250	3/16" x 3-3/4"	Stainless Steel	0.06
OPENLAG250	1/4" x 3-1/2"	Zinc Plated	0.07
OPENLAG250SS	1/4" x 3-1/2"	Stainless Steel	0.07



LHK375X04-NR



J-LAG HOOKS - DROP FORGED, ZINC PLATED

Part #	Size x Shank Length	Thread Direction	Thread Length	Pcs/Pack	Wt (Lbs)/100 Pcs
LHK375X04-NR	3/8" x 4-3/4"	Right	3.50"	200	18
LHK375X04-NL	3/8" x 4-3/4"	Left	3.50"	200	18
LHK500X06-NR	1/2" x 6-1/4"	Right	4.50"	100	38
LHK500X06-NL	1/2" x 6-1/4"	Left	4.50"	100	38
LHK625X07-NR	5/8" x 7-3/8"	Right	5.00"	50	68
LHK625X07-NL	5/8" x 7-3/8"	Left	5.00"	50	68



J-BOLTS - YELLOW ZINC CHROMATE

Part #	Size/Thread	Pieces/Pack	Wt (Lbs)/Pack
J-BOLTS	1/2 - 13	100	20.87



J-BOLTS



DRILL & TAP SCREWS - 7/16 SERRATED WASHER HEAD

2,500 Pc Carton Part #	1,000 Pc Box Part #	Size	Type	Threads/Inch	Point	Wt (Lbs)/1,000 Pcs
C6322-2500	C6322-1000	1/4" x 3/4"	AB	14	#1 Reduced	14.9
C6327-2500	C6327-1000	1/4" x 3/4"	UNC	20	#1 Reduced	15.0
C6326-2500	C6326-1000	1/4" x 1"	AB	14	#1 Reduced	16.4
C6329-2500	C6329-1000	1/4" x 1"	UNC	20	#1 Reduced	17.5
--	C6332-1000	5/16" x 1"	AB	12	#4 Reduced	22.0
--	C6333-1000	5/16" x 1-1/4"	AB	12	#4 Reduced	25.0



C6329



DEEP INDENTED LAG & SMS SCREWS - 7/16 WASHER HEAD

Part #	Size	Type	Threads/Inch	Head	Wt (Lbs)/1,000 Pcs
C6045-1000	1"	A	10	Indented	18.4
C6360-1000	1/4" x 3/4"	AB	14	Serrated	15.0



C6045



C6360





HIGH HAT HEX WASHER HEAD LAG SCREWS - 7/16 WASHER HEAD

Part #	Size	Description	Threads/Inch	Point	Wt (Lbs)/ 1,000 Pcs
C6052-1000	5/16" x 1-5/8"	Full Thread	10	Type A	37.3
C6053-1000	5/16" x 1-3/4"	Full Thread	10	Type A	37.5
C6055-1000	5/16" x 2"	Full Thread	10	Type A	45.8
C6059-500	5/16" x 2-1/2"	Full Thread	10	Type A	49.3
C6061-500	5/16" x 3"	Full Thread	10	Type A	56.7

High Hat heads keep lags in the socket for easier installation.



C6052



HEX HEAD TAP BOLTS - FULLY THREADED

Part #	Size	Type	Threads/Inch	Head	Wt (Lbs)/ 1,000 Pcs
C6102-1000	1/4"-20 x 3/4"	UNC	20	7/16"	14.7
C6104-1000	1/4"-20 x 1"	UNC	20	7/16"	17.8
C6112-1000	5/16"-18 x 3/4"	UNC	18	1/2"	24.4
C6114-1000	5/16"-18 x 1"	UNC	18	1/2"	27.6
C6122-1000	3/8"-16 x 3/4"	UNC	16	9/16"	35.3
C6128-500	3/8"-16 x 1-1/2"	UNC	16	9/16"	56.0



C6112



CARRIAGE BOLTS - FULLY THREADED

Part #	Size	Type	Threads/Inch	Head	Wt (Lbs)/1,000 Pcs
C6072-1000	1/4"-20 x 1-3/4"	UNC	20	Flat	24.0
C6073-1000	1/4"-20 x 1-7/8"	UNC	20	Flat	25.0
C6076-1000	1/4"-20 x 2-1/4"	UNC	20	Flat	29.0
C6078-1000	1/4"-20 x 2-1/2"	UNC	20	Flat	31.5
C6092-1000	1/4 x 20 x 2-1/4	UNC	20	Round	29.0
C6093-1000	1/4"-20 x 1-3/4"	UNC	20	Round	25.0
C6095-1000	5/16"-18 x 3/4"	UNC	18	Round	24.2
C6097-01000	3/8 x 16 x 3/4	UNC	16	Round	48.9



C6073



C6095



SLOTTED TRACK BOLTS - RIB-NECK

Part #	Size	Type	Threads/Inch	Head	Wt (Lbs)/1,000 Pcs
C6142-1000	1/4"-20 x 5/8"	UNC	20	Pan	9.0
C6146-1000	1/4"-20 x 1"	UNC	20	Pan	13.9

Short shoulder rib-neck with low profile pan head.



C6142



C6213



Lin and Jodie



FLAT WASHERS

Part #	Size	Type	Wt (Lbs)/ 1,000 Pcs
C6213-1000	5/16"	USS	11.60
C6214-1000	3/8"	USS	12.80



LOOP NUTS - YELLOW ZINC CHROMATE

Part #	Size/Thread	Pieces/Pack	Wt (Lbs)/Pack
LOOPNUTS	1/2 - 13	100	24.00



LOOPNUTS



FINISHED HEX NUTS

Part #	Size	Type	Threads/Inch	Across Flats	Wt (Lbs)/ 1,000 Pcs
C6160-1000	1/4"-20	UNC	20	7/16"	6.97
C6163-1000	5/16"-18	UNC	18	1/2"	10.60
C6165-1000	3/8"-16	UNC	16	9/16"	15.60



C6163



KEP NUTS

Part #	Size	Type	Threads/Inch	Across Flats	Wt (Lbs)/ 1,000 Pcs
C6201-1000	1/4"-20	UNC	20	7/16"	6.80
C6203-1000	5/16"-18	UNC	18	1/2"	11.60



C6201





SERRATED FLANGE NUTS

Part #	Size	Type	Threads/Inch	Across Flats	Wt (Lbs)/1,000 Pcs
C6211-1000	1/4"-20	UNC	20	7/16"	8.45
C6215-1000	5/16"-18	UNC	18	1/2"	12.70
C6216-1000	3/8"-16	UNC	16	9/16"	18.50



C6215



SLEEVE ANCHORS

Part #	Size	Length	Pack	Wt (Lbs)/Pack
C1405-100	5/16"	1-1/2"	100	4.00
C09431-50	3/8"	1-7/8"	50	4.00
C1433-50	3/8"	3"	50	4.75
C09442-25	1/2"	2-1/4"	25	3.10
C09446-25	1/2"	4"	25	5.10
C09455-10	5/8"	4-1/4"	10	3.88



C09431



WEDGE ANCHORS

Part #	Size	Length	Pack	Wt (Lbs)/Pack
C1031-100	3/8"	2-1/8"	100	8.60



C1031



HAMMER ANCHORS

Part #	Size	Length	Pack	Wt (Lbs)/Pack
C09716-100	1/4"	1-1/4"	100	2.4



C09716

Watch video for more details about Type 304 Stainless Steel Maze Nails



MAZE NAILS - (DOUBLE HOT DIP, 1 LB BOX)*

Part # Smooth	Color	Wt (Lbs)/Ctn
WSNAIL-MS-A-1	Almond	1
WSNAIL-MS-B-1	Brown	1
WSNAIL-MS-S-1	Sandstone	1
WSNAIL-MS-W-1	White	1
WSNAIL-MS-WK-1	Wicker	1



Convenient 1 Lb packages



WSNAIL-MS-W-1



MAZE NAILS - (DOUBLE HOT DIP, 5 LB BOX)*

Part # Smooth	Part # Ring Shank	Color	Wt (Lbs)/Ctn
WSNAIL-MS-A	WSNAIL-MR-A	Almond	5
WSNAIL-MS-B	WSNAIL-MR-B	Brown	5
WSNAIL-MS-S	WSNAIL-MR-S	Sandstone	5
WSNAIL-MS-W	WSNAIL-MR-W	White	5

smooth Shank are 1-1/2"



WSNAIL-MS-A



MAZE NAILS - (TYPE 304 STAINLESS STEEL, 1 LB BOX)*

Part # Smooth	Part # Ring Shank	Color	Wt (Lbs)/Ctn
WSNAIL-SS-A	-	Almond	1
WSNAIL-SS-B	-	Brown	1
WSNAIL-SS-BL	WSNAIL-SR-BL	Black	1
WSNAIL-SS-BRZ	WSNAIL-SR-BRZ	Bronze	1
-	WSNAIL-SR-GN	Green	1
WSNAIL-SS-GY	-	Grey	1
WSNAIL-SS-S	-	Sandstone	1
WSNAIL-SS-W	WSNAIL-SR-W	White	1
WSNAIL-SS-WK	WSNAIL-SR-WK	Wicker	1

Smooth and Ring Shank are 1-1/4"



WSNAIL-SS-BRZ



TRIM NAILS - PAINTED (ALUMINUM ALLOY, 1 LB BOX)*

Part # Smooth	Color	Wt (Lbs)/Ctn
WSNAIL-W	White	1
WSNAIL-GN	Green	1



WSNAIL-W

* Additional colors are available. Call 800.431.3095 for details.

FEHR LUBRICANTS



FEHR HAS BEEN TRUSTED FOR OVER 35 YEARS TO PROVIDE THE BEST LUBRICANTS. THE NEWEST MEMBERS TO THE LINE-UP INCLUDE HIGH PURITY FOOD GRADE GREASE, FOOD GRADE DRY SILICONE SPRAY AND PTFE ULTRA LUBE.



L6930

- Penetrating Oil
- Penetrant
- Lubricates
- Prevents corrosion
- Frees frozen parts
- Mineral oil
- 0 to 300 ° F
- 50 State VOC compliant
- Available as private label

L6940

- High Purity Food Grade Grease
- Food grade lubricant
- Excellent for high load applications requiring a long grease life
- Calcium sulfonate
- -40° to 550 ° F
- 50 State VOC compliant
- NSF H1 Food Grade
- Available in spray, cartridge and pail

L6950

- Multi-Purpose Lubricant
- Sprays on like foam
- Sets up to a tough protective grease in minutes
- Ideal for hard to reach areas
- Lithium based
- 0 to 350 ° F
- 50 State VOC compliant
- Available as private label

L6960

- PTFE Multi-Purpose Lube
- Sprays on like oil
- Sets up to a thick grease
- High pressure spray for hard to reach areas
- PTFE remains on surface
- PTFE
- -30° to 600 ° F
- Non-Chlorinated
- 50 State VOC compliant
- Available as private label

L6980

- Dry Silicone Spray
- Lubricates
- Waterproofs
- Colorless and odorless
- Repels dirt and grime
- No sticky residue
- -35° to 550 ° F
- 50 State VOC compliant
- NSF H1 Food Grade

Private Labelling Program:

- Available on all Fehr Lubricants except those that require NSF certification
- 30 case minimum
- No charge for artwork
- Send art as PDF or JPEG

Please see flyer on cleaning procedure for Lubricants





FEHR LUBRICANTS **MADE IN USA**

Part #	Description	Size (Oz)	Cans/Case	Label Color	Wt (Lbs)/Case
L6950	Multi-Purpose Spray Lube	15.0	12	Green	14.5
L6960	PTFE Lube	14.0	12	Blue/Silver	16.2
L6940	NSF Food Grade White Grease Spray	11.0	12	Orange	11.0
L6940T	NSF Food Grade Grease Cartridge	14.5	10	Orange	9.0
L6980	NSF Food Grade Dry Silicone	11.5	12	Purple	12.4
L6930	Penetrating Oil	15.0	12	Red	15.3



LUBRIPLATE

Part #	Description	Net Wt /Oz	Tubes/Cs	Master Carton	Wt (Lbs)/Cs
LP-LT	Low Temp Lithium Grease	10	12	36	19.2
LP-AERO	Aero Grade Grease	1-3/4	12	36	3.1



LP-AERO



LP-LT



SLICKIT

Part #	Description	Net Wt /Oz	Sticks/Cs	Wt (Lbs)/Cs
SLICKIT	Weatherseal Flex Lubricant	2.5	8	2.0



SLICKIT



HAND CLEANER TOWELS **MADE IN USA**

Part #	Description	Towel Count	Size	Master Carton	Wt (Lbs)/Case
FEHRTOWELS	Heavy Duty 2-sided Wipes	110	8" x 12"	4	2.40
SCRUBS	Hand Cleaner Towels	72	10-1/2" x 12-1/4"	6	2.83

Abrasive side cuts through tough soils, smooth side wipes delicate surfaces.



FEHRTOWELS



Loosens, dissolves and absorbs dirt and grease leaving hands clean.



SCRUBS





Visit SLIPIT website for more information

SLIPIT Professional Grade Lubricant

Because friction is bad for business

That's why professionals in almost every industry - from elevators and trucks to overhead doors - have been turning to SLIPIT as their lubricant of choice for over 70 years. SLIPIT was proven to be superior - no contest - as the best lubricant for load-carrying and wear reduction in rigorous independent testing performed at RPI, one of the top rated engineering schools in the U.S. SLIPIT is NSF (H1) approved for incidental food contact, for use in and around food processing areas. Easily applied in compound, spray, or liquid, you'll want to turn to odorless, non-toxic, safe SLIPIT.

Because friction is bad for any business. Especially yours.



Nonfood Compounds
H1



Slipit® Lubricant

Part #	Description	Size	Wt (Lbs)/Ea
SLIPIT-G	Slipit Sliding Compound	1 Gallon Pail	8.3
SLIPIT-5G	Slipit Sliding Compound	5 Gallon Pail	39.2
SLIPIT-P	Slipit Sliding Compound	1 Pint Can	1.13
SLIPIT-Q	Slipit Sliding Compound	1 Quart Can	2.25



SLIPIT-G





Nonfood Compounds
H1



Slipit® Silicone Free Gel Lubricant

Part #	Description	Size	Wt (Lbs)/Ea
SLIPIT-SF-5GALLON50447	Slipit Sliding Compound	5 Gallon Pail	8.3
SLIPIT-SF-GALLON10447	Slipit Sliding Compound	1 Gallon Pail	7.9
SLIPIT-SF-5GALLON50595	Slipit Liqui-form	5 Gallon Pail	39.2



SLIPIT-SF-GALLON10447



Slipit® Silicone Free Gel Lubricant

Part #	Description	Size	Wt (Lbs)/Ea
SLIPIT-SF-QUART32447	Slipit Sliding Compound	1 Quart Can	2.27
SLIPIT-SF16447	Slipit Sliding Compound	1 Pint Can	1.10
SLIPIT-SF40447	Slipit Sliding Compound	4 oz.	0.26



SLIPIT-SF-QUART32447



Slipit® Silicone Free Tool Lubricant

Part #	Description	Size	Cans/Case	Wt (Lbs)/Ea
SLIPIT-TOOL11236X12	Slipit Spray Lube	11 oz.	12	1.00



SLIPIT-TOOL11236



Slipit® Spray Lubricant

Part #	Description	Size	Cans/Case	Wt (Lbs)/Ea
SLIPIT-SPRAY	Slipit Spray Lube	11 oz.	12	1.00
SLIPIT-SPRAYX1	Slipit Spray Lube	11 oz.	1	1.00



SLIPIT-SPRAY



Slipit® Lubricant Liquid Spray

Part #	Description	Size	Wt (Lbs)/Ea
SLIPIT-SF-PUMP16595	Silicone Free Liqui-Form	1 Pint	1.1
SLIPIT-SF-PUMP32595	Silicone Free Liqui-Form	1 Quart	1.9
SLIPIT-PUMP32710	LW Liquid	1 Quart	1.13



SLIPIT-SF-PUMP16595

GARAGE DOOR HARDWARE



Fehr Bros. provides the highest quality door rollers. Our side by side cycle testing demonstrates that Fehr rollers complete 2-3 times as many cycles as the competition and show only half the wear. Dare to compare! Go to www.fehr.com for cycle test data.



2" WHITE NYLON - 13 BALL

Part #	Stem Length	Cycles-12' Door 125 Lb Load	Bulk	Dealer Pack	Bag	Wt (Lbs)/Ea
ROLL26NL	4" Zinc	20,000	150	-	10	0.30
ROLL26NL-XL	7" Zinc	20,000	100	-	10	0.44
ROLL26NL-XXL	9" Zinc	20,000	-	50	-	0.50



ROLL26NL



2" WHITE NYLON - 13 BALL CAPPED

Part #	Stem Length	Cycles-12' Door 125 Lb Load	Bulk	Dealer Pack	Bag	Wt (Lbs)/Ea
ROLL26CAP	4" Zinc	20,000	150	-	10	0.31
ROLL26CAP-XL	7" Zinc	20,000	100	50	-	0.44



ROLL26CAP



2" WHITE NYLON - 11 BALL

Part #	Stem Length	Cycles-12' Door 125 Lb Load	Bulk	Dealer Pack	Bag	Wt (Lbs)/Ea
ROLL11NLX150	4" Zinc	20,000	150	-	10	0.32
ROLL11NL-XL	7" Zinc	20,000	100	-	-	0.44



ROLL11NL-XL



2" BLACK NYLON - BEARINGLESS

Part #	Stem Length	Cycles-8' Door 50 Lb Load	Bulk	Dealer Pack	Bag	Wt (Lbs)/Ea
ROLL8	4" Zinc	10,000	200	50	-	0.23



ROLL8





2" PRECISION BEARING - 6200Z

Part #	Stem Length	Cycles-12' Door 150 Lb Load	Bulk	Bag	Wt (Lbs)/Ea
ROLL41	4" Zinc	100,000	150	10	0.30
ROLL41-XL	7" Zinc	100,000	100	-	0.44



ROLL41



**2" SEALED PRECISION BEARING -
6200-2RS (304 SS STEM)**

Part #	Stem Length	Cycles-12' Door 150 Lb Load	Bulk	Pieces	Bag	Wt (Lbs)/Ea
ROLL50CW-XL	7" SS	100,000	100	1	-	0.44
ROLL50CW-XXL	9" SS	100,000	100	1	-	0.75



ROLL50CW-XL



2" STEEL - 10 BALL

Part #	Stem Length	Cycles-12' Door 75 Lb Load	Bulk	Dealer Pack	Bag	Wt (Lbs)/Ea
ROLL4	4" Zinc	15,000	100	-	10	0.32
ROLL26L-DP	7" Zinc	15,000	-	50	-	0.44
ROLL26XL	9" Zinc	15,000	100	50	-	0.56



ROLL26L



2" STEEL - 7 BALL

Part #	Stem Length	Cycles-8' Door 35 Lb Load	Bulk	Dealer Pack	Bag	Wt (Lbs)/Ea
ROLL9	4" Zinc	10,000	200	50	-	0.23



ROLL9



Tim



3" STEEL - 10 BALL

Part #	Stem Length	Cycles-12' Door 150 Lb Load	Bulk	Dealer Pack	Bag	Wt (Lbs)/Ea
ROLL27	4" Zinc	50,000	-	24	-	0.63
ROLL28-DP	7" Zinc	50,000	-	24	-	0.66
ROLL28XL	9" Zinc	50,000	-	24	-	0.74



ROLL28XL



3" PRECISION BEARING - 6200ZZ (CARRIAGE HOUSE)

Part #	Stem Length	Cycles-12' Door 150 Lb Load	Bulk	Dealer Pack	Pc	Wt (Lbs)/Ea
ROLL3XL	7" Zinc	100,000	50	-	1	0.59
ROLL3XXL	9" Zinc	100,000	50	-	1	0.68



ROLL3XL



3" SEALED PRECISION BEARING - 6203-2RS (304 SS STEM)

Part #	Stem Length	Cycles-12' Door 150 Lb Load	Bulk	Dealer Pack	Pc	Wt (Lbs)/Ea
ROLL5XL	7" SS	100,000	50	-	1	0.61
ROLL5XXL	9" SS	100,000	50	-	1	0.75
*ROLL5CAP-XL	7" SS	100,000	50	-	1	0.65



ROLL5XXL



*Capped Nylon Roller



HIGH STRENGTH 80,000 PSI POWDER COATED ANGLE

Part #	Gauge	Description	Color	Bulk	Dealer Pack	Wt (Lbs)/Ea
PERF12-8.25W	12	1-1/4 x 1-1/4 x 8'3"	White	320	10	5.80
PERF12-8.25P	12	1-1/4 x 1-1/4 x 8'3"	Gray	320	10	5.80
PERF12-8.25BL	12	1-1/4 x 1-1/4 x 8'3"	Black	320	10	5.80

Powder coated in gray or white, cut with chop saw or Roper Whitney angle shear



PERF12-8.25W

Roper Whitney Angle Shear on pg 42.



TRWAC-4



HOT DIPPED GALVANIZED PERFORATED ANGLE

Part #	Gauge	Description	Color Code	Bulk	Half Pack	Dealer Pack	Wt (Lbs)/Ea
PERF12-8	12	1-1/4 x 1-1/4 x 8'	Yellow	200	100	10	5.6
PERF12-10	12	1-1/4 x 1-1/4 x 10'	Yellow	200	100	10	6.7
PERF12X2-10	12	2 x 2 x 10'	Brown	200	100	10	12.0
PERF13-8	13	1-1/4 x 1-1/4 x 8'	Red	200	100	10	4.4
PERF14-10	14	1-1/4 x 1-1/4 x 10'	Green	200	100	10	5.2
PERF16-8	16	1-1/4 x 1-1/4 x 8'	Blue	200	100	10	3.7

Full G90 galvanizing, holes are 1" on center

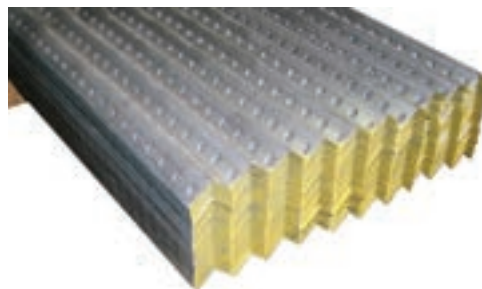

PERF12-8

Tool on pg 42.



THDPRO



Fehr hinges are deburred before plating to insure smooth clean edges. Roller tubes are welded. On 11 and 14 gauge hinges four additional holes are punched to allow the use of additional fasteners for increased attachment strength.



11 GAUGE HINGES - COMMERCIAL & INDUSTRIAL

Size #	Part # Bulk	Bulk	Part # Dealer Pack	Dealer Pack	Wt (Lbs)/Ea
1	GDHINGE11-1X50	50	GDHINGE11-1-DP	24	0.63
2	GDHINGE11-2X50	50	GDHINGE11-2-DP	12	0.74
3	GDHINGE11-3X50	50	GDHINGE11-3-DP	12	0.80
4	GDHINGE11-4X50	50	GDHINGE11-4-DP	12	0.82
5	GDHINGE11-5X50	50	GDHINGE11-5-DP	12	0.85
6	GDHINGE11-6X50	50	GDHINHE11-6-DP	12	0.89
7	GDHINGE11-7	1	-	-	0.92
8	GDHINGE11-8	1	-	-	0.95
9	GDHINGE11-9	1	-	-	0.96

Heavy duty for commercial and industrial doors



GDHINGE11-1



14 GAUGE HINGES - RESIDENTIAL

Size #	Part # Bulk	Bulk	Part # Dealer Pack	Dealer Pack	Wt (Lbs)/Ea
1	GDHINGE14-1	100	GDHINGE14-1-DP	50	0.43
2	GDHINGE14-2	100	GDHINGE14-2-DP	25	0.53
3	GDHINGE14-3	100	GDHINGE14-3-DP	25	0.55
4	GDHINGE14-4	100	GDHINGE14-4-DP	25	0.56
5	GDHINGE14-5	100	GDHINGE14-5-DP	25	0.65

Available in bulk and dealer packs



GDHINGE14-1



14 GAUGE HINGES - BLACK POWDER COATED

Size #	Part # Bulk	Part # Dealer Pack	Dealer Pack	Wt (Lbs)/Ea
1	GDHINGE14-1BL	GDHINGE14-1BL-DP	50	0.38
2	GDHINGE14-2BL	GDHINGE14-2BL-DP	50	0.46
3	GDHINGE14-3BL	GDHINGE14-3BL-DP	50	0.47



GDHINGE14-1BL



14 GAUGE HALF HINGE

Part #	Size #	Single Dealer Pack	Wt (Lbs)/Ea
GDHINGE14-N	1	1	0.30

Used on full view doors



GDHINGE14-N



18 GAUGE HINGES - NARROW DESIGN

Size #	Part # Bulk	Part # Dealer Pack	Dealer Pack	Wt (Lbs)/Ea
1	GDHINGE18-1	GDHINGE18-1-DP	50	0.23
2	GDHINGE18-2	GDHINGE18-2-DP	50	0.29
3	GDHINGE18-3	GDHINGE18-3-DP	50	0.36

Narrow design for light-weight doors



GDHINGE18-1



TOP BRACKETS

Part #	Description	Dealer Pack	Wt (Lbs)/Ea
RESBRAC-DP	Residential	24	0.47
RESBRACW	Residential (White)	1	0.29
COMBRAC-DP	Commercial	24	0.92

Roller carriers are double bolted



RESBRAC-DP



COMBRAC-DP



O&E LOW HEADROOM KIT

Part #	Description	Dealer Pack	Wt (Lbs)/Ea
LHROEKIT	Low Headroom	1	4.10

Works with 7' or 8' doors with torsion or extension springs

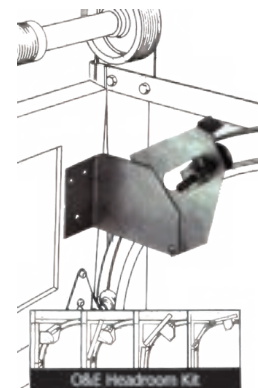

LHROEKIT



LOW HEADROOM TOP CARRIER

Part #	Description	Dealer Pack	Wt (Lbs)/Ea
LHRCAR-DP	Low Headroom	24	0.46

12 GA,
heavy duty



LHRCAR-DP



QUICK CLOSE BRACKET

Part #	Description	Dealer Pack	Wt (Lbs)/Ea
QWIK-DP	Low Headroom	10 Pc	2.20

Reduces
headroom
requirement
by up to
2-1/2"



QWIK-DP



OPERATOR REINFORCEMENT BRACKETS

Part #	Description	Size	Dealer Pack	Wt (Lbs)/Ea
ORB18-DP	One pc-Galvanized	18"	12	1.8
ORB21-DP	One pc-Galvanized	21"	12	2.3
ORB21W-DP	One pc-White	21"	12	2.3
ORB24-DP	One pc-Galvanized	24"	12	2.6

One piece
design is
2-5/8" wide



ORB21W-DP



ADJUSTABLE REINFORCEMENT BRACKETS

Part #	Description	Size	Dealer Pack	Wt (Lbs)/Ea
ORBADJ-N-DP	Narrow Design	Adj	16	0.47

Fits 18"-24"
sections



ORBADJ-N-DP



ORBADJ-DP



NARROW REINFORCEMENT BRACKETS

Part #	Description	Size	Dealer Pack	Wt (Lbs)/Ea
ORB20W-DP	One pc-White	18"-21"	16	1.1

15/16" wide
for use with
narrow
mullions



ORB20W-DP



Fehr's selection of bottom brackets can be used on standard residential and commercial doors. Available in convenient carton quantities.



BOTTOM BRACKETS FOR 2" TRACK

Part #	Description	Gauge	Height	Pin Style	Side Flange	Bottom Flange+++	Dealer Pack	Wt (Lbs)/Pr
BB100	Residential	13	5-11/16"	Milford	1-1/4"	-	25 Pr	1.2
BB12	Commercial	12	7-1/2"	Clevis	1-1/4"	1-1/4"	12 Pr	2.3
BB7	HD Commercial	11	8-3/8"	Clevis	1-5/8"	1-5/8"	12 Pr	4.3

Clevis pin bottom brackets typically use a thimble loop assembly



Milford pin bottom brackets require plain loop cable assemblies



LHR bottom brackets allow cable attachment outside of the vertical track



BOTTOM BRACKETS FOR LOW HEADROOM TRACK

Part #	Gauge	Height	Pin Style	Side Flange	Track	Dealer Pack	Wt (Lbs)/Pr
BB5-DP	11	6-1/2"	Clevis	-	2"	12 Pr	2.7



BOTTOM BRACKETS FOR 3" TRACK

Part #	Gauge	Height	Pin Style	Side Flange	Bottom Flange	Dealer Pack	Wt (Lbs)/Pr
BB9-DP	12	8-3/8"	Clevis	1-5/8"	1-5/8"	6 Pr	2.9





CLEVISBAG



Theresa and Debbie



CLEVIS WITH COTTER PIN

Part #	Description	Pin Style	Dealer Pack	Wt (Lbs)/Pr
*CLEVISBAG	5/16 X 15/16	Clevis	25 Set	1.24

*Use with Bottom Brackets



LIFT HANDLES

Part #	Description	Gauge	Dealer Pack	Wt (Lbs)/Ea
RGHANDLE-DP	Rolled Grip	16	50	0.18

16 gauge ,
zinc plated



RGHANDLE-DP



STEP PLATES

Part #	Description	Gauge	Dealer Pack	Wt (Lbs)/Ea
STEP-DP	2 Hole	11	1	0.21

1-1/2" x 1-1/2"
x 4-1/2" long



STEP-DP



JAMB BRACKETS

Part #	Description	Pack	Wt (Lbs)/Ea
J1-DP	J1-12 Gauge Jamb Bracket	10	0.22
J3-DP	J3-12 Gauge Jamb Bracket	10	0.30
J4-DP	J4-12 Gauge Jamb Bracket	10	0.31
J5-DP	J5-12 Gauge Jamb Bracket	10	0.34
J6-DP	J6-12 Gauge Jamb Bracket	10	0.36
J7-DP	J7-12 Gauge Jamb Bracket	10	0.36

12 gauge ,
zinc plated



J1-DP

Fehr lock components provide a range of alternative locking systems including cable or chain activated Snap Latch, single or double Lock Bar, or Side Lock systems for replacement and new installation.



SIDE LOCKS

Part #	Description	Bulk	Bag	Wt (Lbs)/Ea
LS146	2" Side Lock	100	1	0.46
LS147	3" Universal	60	1	0.47



LS146



PLAIN T - HANDLE SET

Part #	Description	Bulk	Dealer Pack	Bag	Wt (Lbs)/Ea
LS2S	Plain T Handle-Square Shaft	100	10	1	0.53
LS2S-KIT	Plain T Handle Installation Kt	100	10	1	1.54



LS147



LS2S



Cylinders are available in random keyed or keyed alike



LS7



LOCKING HANDLES & CYLINDERS

Part #	Description	Bulk	Dealer Pack	Bag	Wt (Lbs)/Ea
LS3R	Locking T-Handle Set	100	10	1	0.67
LS3B	Blind Mount Locking T-Handle	100	10	1	0.67
LS3LSP	L-Handle Cylinder Combo	50	10	1	0.82
LS3LSP-KIT	L Handle & Cyl Combo Kit			1	2.10
LS7	Zinc Die Cast Rim Cylinder	100	10	1	0.34
LS6R	Locking Side Latch Mechanism	-	-	1	1.10



LS3R



LS3B

LS3LSP and LS6R are designed to be used in tandem



LS3LSP

LS6R





LS68

Traditional cast body for wood doors



DEADBOLT SETS

Part #	Description	Bulk	Dealer Pack	Bag	Wt (Lbs)/Ea
LS68	Cast Deadbolt Set	80	10	1	0.80



LATCHES & STRIKERS

Part #	Description	Bulk	Dealer Pack	Bag	Wt (Lbs)/Ea
LATCH	Zinc Plated Spring Latch	50	10	1	0.49
STRIKER	Zinc Plated Striker Plate	50	10	1	0.16



STRIKER

Use trackbolts to attach to vertical track



Keyhole for easy cable attachment



LATCH



ILSWIV



INSIDE HANDLES

Part #	Description	Bulk	Dealer Pack	Bag	Wt (Lbs)/Ea
ILSWIV	Inside Swivel	200	10	1	0.21



DEAD BOLT COMPONENTS

Part #	Description	Bulk	Dealer Pack	Bag	Wt (Lbs)/Ea
LBD1	#1 Lock Bar Disc - Square Hole	100	10	1	0.41
LBS360-DP	Lock Bar Spring	100	10	1	0.03
3GUIDE-DP	#3 Lock Bar Guide	100	10	1	0.05
LBADD	Lock Bar Adder Bag	100	10	1	0.25
LBD5	#5 Lock Bar Disc - square Hole	100	10	1	0.19



LBD1



LBS360-DP



3GUIDE-DP



LOCK BARS

Part #	Description	Bulk	Dealer Pack	Bag	Wt (Lbs)/Ea
LB50	50" Lock Bar Hemmed Pattern	100	10	1	1.17
LBA50-5	Lock Bar Assembly with #5 Disc and 2-50" Bars	100	10	1	2.50
LBA55.75	Lock Bar Assembly with #5 Disc and 2-50-3/4" Bars	100	10	1	2.75
LBA98-5	Lock Bar Assembly with #5 Disc and 2 -98" Bars	100	10	1	4.74



LB50



KEY SWITCHES & KEY DISCONNECT DEVICES

Part #	Description	Bulk	Dealer Pack	Bag	Wt (Lbs)/Ea
EKIT-100	Metal Key Switch	100	10	1	0.24
EKIT-102	Keyed Disconnect Device	100	10	1	0.28
EKIT-103	Blind Mount Keyed Disconnect Device	100	10	1	0.50



EKIT-100



EKIT-102



EKIT-103



SNAP-LATCH COMPONENTS

Part #	Description	Bulk	Dealer Pack	Bag	Wt (Lbs)/Ea
39501-60	3/32" x 60" Latch Cable with Stop	100	10	1	0.41
39501-108	3/32" x 108" Latch Cable with Stop	100	10	1	0.19
SASH9BAG	#8 x 4-1/2' EG Sash Chain (In Bag)	100	10	1	0.03
SASH16BAG	#8 x 8' EG Sash Chain (In Bag)	100	10	1	0.05
EGSH125-DP	1/8 x 1" EG S-Hook	1000	100	1	0.25
EGSASH8X100	#8 X 100 FT Sash Chain	-	-	-	0.04
EGSASH8X500	#8 X 500 FT Sash Chain	-	-	-	0.04



39501-60



SASH9BAG



EGSH125-DP

Double latch kits include all inside hardware required to lock both sides



LBAG-16D-CHA



LBAG-16D-CAB

PRE-PACKAGED LOCK SETS

Part #	Description	Bulk	Dealer Pack	Bag	Wt (Lbs)/Ea
LBAG-16D-CAB	16' Door Double Spring Latch-Cable	100	10	1	1.96
LBAG-16S-CHA	16' Door Single Spring Latch-Chain	100	10	1	1.27

END BEARING PLATES

Part #	Description	Offset	Gauge	Pack	Wt (Lbs)/Pr
EBFPLTEX25	338 End Bearing Plate with Flange	3-3/8"	12	25 Pr	1.68
EBF438	438 End Bearing Plate with Flange	4-3/8"	8	Pr	3.66
EBF500	500 End Bearing Plate with Flange	5.0"	8	Pr	5.14

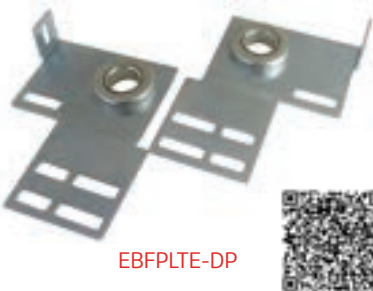

EBFPLTE-DP



EBF438



EBF500

FLAT END BEARING PLATES

Part #	Description	Length	Gauge	Pack	Wt (Lbs)/Pr
ENDPLTE-DP	#2 Flat End Bearing Plate	6-5/8" OAL	8	24 Pc	1.07/Ea

Mounts to horizontal track angle



ENDPLTE-DP

Fits most 10", 12" and 15" radius tracks



UNIDEC

DECORATOR ANGLES

Part #	Description	Finish	Gauge	Pack	Wt (Lbs)/Pr
UNIDEC	Universal Decorator / Flag Bracket	Zinc	14	Pr	2.55

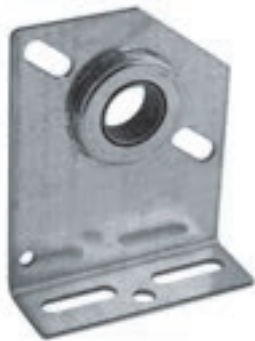

SPRGPLTE-DP



RESI-SPRGPLTE-DP



SPRING ANCHOR PLATES

Part #	Description	Offset	Gauge	Pack	Wt (Lbs)/Ea
RESI-SPRGPLTE-DP	Residential Universal	Adj	12	50	0.60
CENTRPLTE-DP	338 Center Bearing Plate	3-3/8"	8	24	1.69
SPRGPLTE-DP	338 Spring Anchor Plate	3-3/8"	11	24	0.90
NOTCHPLTE-DP	338 Notched Anchor Plate	3-3/8"	11	50	0.66
USA-SPRGPLTE-L	Commercial Universal - Left	Adj	8	Ea	1.59
USA-SPRGPLTE-R	Commercial Universal - Right	Adj	8	Ea	1.59



CENTRPLTE-DP



USA-SPRGPLTE-L



BEARINGS

Part #	Description	Bulk	Pack	Wt (Lbs)/Ea
BEAR18-DP	2" x 1" Nylon Flanged Bushing	100	50	0.68
BEAR23-DP	2" x 1" Steel Flanged Bearing	100	24	0.39
BEAR32	2" x 1" Bearing in Football Plate	-	1	0.22



BEAR18-DP



BEAR23-DP



BEAR32



STAMPED SHEAVES

Part #	Description	Max Load Rating (Lbs)	Bulk	Pack	Wt (Lbs)/Ea
SHV3HD	3" Heavy Duty	100	-	24	0.334
SHV3HDGOLDX50	3" Extra Heavy Duty	200	-	50	0.40
SHV4	4" Heavy Duty	200	-	10	0.72
SHV4STUD	4" Heavy Duty with Stud	200	-	10	0.92



SHV3HDGOLDX50

SHV3HD



SHV4



SHV4STUD



CAST SHEAVES

Part #	Description	Max Load Rating (Lbs)	Bulk	3" Dealer Pack	Pack	Wt (lbs)/Ea
SHV3CAST	3" Cast Iron Sheave	300	50	20	1	0.66
SHV4CAST	4" Cast Iron Sheave	400	30	-	1	1.07



Cast iron sheaves use a shielded precision bearing



SHV3CAST



SHV4CAST



SHV3FORK-DP



SHEAVE FORKS

Part #	Description	Pack	Wt (Lbs)/Ea
SHV3FORK-DP	3" Sheave Fork	24	0.07
SHV3FORKRESX50	3" Sheave Fork with Safety Cable	50	0.09
SHV4FORK-DP	4" Sheave Fork	10	0.2



SHV3FORKRESX50





SHEAVE KITS

Part #	Description	Max Load Rating (Lbs)	Pack	Wt (Lbs)/Ea
SHV3HDKIT	3" Heavy Duty Sheave Kit	100	24	0.47
SHV4KIT	4" Sheave Kit	200	10	0.99
PULADD	Pulley Kit Adder Bag			0.83

Includes 3" HD sheave, fork, 3/8" x 1-1/2" bolt and nut



SHV3HDKIT



Includes 4" sheave, fork, 3/8" x 1-1/2" bolt and nut



SHV4KIT



CHAIN HOISTS

Part #	Description	Ratio	Pack	Wt (Lbs)/Ea
CH84	Chain Hoist - Shaft Mount Reduced Drive	4:1	1	16.6
CH88	Chain Hoist - Wall Mount Reduced Drive	4:1	1	16.6
CH-CHAINX21	Hand Chain for CH84, CH88	-	21'	8.4
CH-CHAINX26	Hand Chain for CH84, CH88	-	26'	10.5
CH-CHAINX250	Bulk Hand Chain for Chain Hoists	-	250'	78
CH-SPROCKETKIT	6", 36 Tooth Sprocket Wheel & 3 Ft of # 41 Roller Chain	-	1	

Hoists include 26 Ft of hand chain and 3 Ft of #41 roller chain



CH84



CH88



CH-SPROCKETKIT



SPREADER BAR

Part #	Description	Pack	Wt (Lbs)/Ea
CH-JSS	Adjustable Jack Shaft Spreader Arm	1	5.2

Includes 2 shaft collars



CH-JSS

Fehr cable assemblies are fuse cut and machine swaged using aluminum fittings. They are coiled in pairs and color coded. Assemblies with thimbles, CC1 clips, spool eyes and copper fittings are available. Custom assemblies are also available in 304 or 316 stainless.



CABLES FOR 7' HIGH TORSION DOORS

Part #	Size	Type	Length	Loop	Wt/Pr
36601-102	3/32"	7x7	102"	Plain	0.15
36602-102	1/8"	7x7	102"	Plain	0.52
36602-104	1/8"	7x7	104"	Plain	0.54
36612-102	1/8"	7x19	102"	Plain	0.52
36612-104	1/8"	7x19	104"	Plain	0.54
36612-102S	1/8"	7x19 SSAC	102"	Plain	0.52



36602-102



CABLES FOR 8' HIGH TORSION DOORS

Part #	Size	Type	Length	Loop	Wt/Pr
36601-114	3/32"	7x7	114"	Plain	0.32
36602-114	1/8"	7x7	114"	Plain	0.56
36612-114	1/8"	7x19	114"	Plain	0.58
36612-114S	1/8"	7x19 SSAC	114"	Plain	0.58
36672-114	1/8"	7x19	114"	Plain with Floating Stop	0.59



36601-114



CABLES FOR TALLER TORSION DOORS

Part #	Size	Type	Length	Loop	Door Height	Wt/Pr
36602-126	1/8"	7x7	126"	Plain	9'	0.64
36612-126	1/8"	7x19	126"	Plain	9'	0.64
36602-138	1/8"	7x7	138"	Plain	10'	0.70
36602-162	1/8"	7x7	162"	Plain	12'	0.82



36602-138





NOTE: Cable fitting sleeves and stops are available on Pg. 20-21.



CABLES FOR 7' HIGH EXTENSION DOORS

Part #	Size	Type	Length	Loop	Wt/Pr
36001-120	3/32"	7x7	120"	Plain	0.33
36001-144	3/32"	7x7	144"	Plain	0.40
36001-150	3/32"	7x7	150"	Plain	0.42
36002-120	1/8"	7x7	120"	Plain	0.60
36002-144	1/8"	7x7	144"	Plain	0.72
36003-144	5/32"	7x7	144"	Plain	1.15
36012-144	1/8"	7x19	142"	Plain	0.72



36001-144



CABLES FOR 8' HIGH EXTENSION DOORS

Part #	Size	Type	Length	Loop	Wt/Pr
36001-156	3/32"	7x7	156"	Plain	0.44
36002-156	1/8"	7x7	156"	Plain	0.78
36012-156	1/8"	7x19	156"	Plain	0.78
36112-156	1/8"	7x19	156"	Thimble	0.81
36402-156	1/8"	7x7	156"	CC1	0.84
36412-156	1/8"	7x19	156"	CC1	0.91
36013-156	5/32"	7x19	156"	Plain	1.21



36002-156



CABLES FOR TALLER EXTENSION DOORS

Part #	Size	Type	Length	Loop	Door Height	Wt/Pr
36001-164	3/32"	7x7	164"	Plain	13'	0.46
36001-168	3/32"	7x7	168"	Plain	9'	0.47
36002-168	1/8"	7x7	168"	Plain	9'	0.84
36012-168	1/8"	7x19	168"	Plain	9'	0.84
36013-168	5/32"	7x19	168"	Plain	9'	1.31
36112-168	1/8"	7x19	168"	Thimble	9'	0.87
36412-168	1/8"	7x19	168"	CC1	9'	0.98



36012-168



Fehr torsion springs are manufactured from oil-tempered spring wire meeting ASTM A229. Wire is coated for improved corrosion resistance and easier handling. Standard 10,000 cycle and 25,000+ High Cycle Springs are available in both left or right wound, precut with fittings installed or in long lengths.



1-3/4" ID PRE-CUT, FITTINGS INSTALLED - 7' HIGH DOORS - 4" DRUM

Part # Left	Part # Right	Lbs	Size	IPPT Rate	Color Code	Wt (Lbs)/Ea
TORA-080L	TORA-080R	80	.207 x 25"	23.83	Yellow	7.1
TORA-090L	TORA-090R	90	.207 x 22.5"	26.61	Yellow	6.4
TORA-100L	TORA-100R	100	.218 x 26"	30.01	White	7.8
TORA-110L	TORA-110R	110	.225 x 27.5"	32.56	Red	8.5
TORA-120L	TORA-120R	120	.234 x 30"	36.08	Brown	9.7
TORA-130L	TORA-130R	130	.234 x 28"	38.76	Brown	9.1
TORA-140L	TORA-140R	140	.243 x 35.5"	41.88	Green	10.7
TORA-150L	TORA-150R	150	.250 x 33"	45.23	Gold	11.5
TORA-160L	TORA-160R	160	.262 x 39.5"	47.7	Blue	14.6
TORA-170L	TORA-170R	170	.262 x 37"	51.04	Blue	13.6
TORA-180L	TORA-180R	180	.262 x 35"	54.07	Blue	12.9

Left wound springs have black color-coded winding sleeves



TORA-070L

Right wound springs have red color-coded winding sleeves



Safety Collars and Winding Bars on pg 42.



SAFETY COLLAR



WINDING BAR

Fehr high cycle torsion springs are designed to work on 7' high doors as "High Cycle" or 8' doors as standard 10,000 cycle springs. With fewer turns (7.6 vs. 8.8) they lift less door weight per turn and as a consequence last considerably longer. Calculated cycles are shown.



**1-3/4" ID PRE-CUT, FITTINGS INSTALLED - 7' HIGH DOORS
- 4" DRUM (HIGH CYCLE)**

Part # Left	Part # Right	Lbs	Size	IPPT Rate	Color Code	Wt (Lbs)/Ea
TORA192X26.5L	TORA192X26.5R	55	.192 x 26.5"	15.47	Orange	7.58
TORA207X31L	TORA207X31R	65	.207 x 31"	19.06	Yellow	9.46
TORA207X28L	TORA207X28R	70	.207 x 28"	21.18	Yellow	8.61
TORA207X25.5L	TORA207X25.5R	80	.207 X25.5"	23.35	Yellow	7.90
TORA218X31L	TORA218X31R	85	.218 x31"	24.99	White	10.01
TORA218X28L	TORA218X28R	95	.218 x 28"	27.78	White	8.96
TORA225X29L	TORA225X29R	105	.225 x 29"	30.81	Red	9.40
TORA234X32L	TORA234X32R	110	.234 x 32"	33.74	Brown	10.80
TORA234X35L	TORA234X35R	130	.234 X 35"	30.7	Brown	12.01
TORA243X32L	TORA243X32R	140	.243 X 32"	41.2	Green	11.60
TORA243X33L	TORA243X33R	145	.243 X 33"	39.9	Green	11.19
TORA243X35L	TORA243X35R	125	.243 x 35"	37.54	Green	12.00
TORA250X35L	TORA250X35R	145	.250 X 35"	42.55	Gold	12.30
TORA250X39L	TORA250X39R	130	.250 x 39"	38.04	Gold	13.70
TORA262X38L	TORA262X38R	165	.262 X 38"	58.58	Blue	14.01
TORA262X40L	TORA262X40R	160	.262 X 42"	47.08	Blue	15.20
TORA262X43L	TORA262X43R	150	.262 X 43"	43.69	Blue	16.50
TORA262X45.5L	TORA262X45.5R	140	.262 x45.5"	41.22	Blue	17.20
TORA273X39L	TORA273X39R	195	.273 X 39"	58.58	Orange	15.10
TORA273X44L	TORA273X44R	175	.273 X 44"	51.71	Orange	17.54
TORA283X50L	TORA283X50R	180	.283 x 50"	54.05	Light Blue	20.74



TS-ST

Spring Tools on pg 42.



1-3/4" ID PRE-CUT, FITTINGS INSTALLED - 8' HIGH DOORS - 4" DRUM

Part # Left	Part # Right	Lbs	Size	IPPT Rate	Color Code	Wt (Lbs)/Ea
TORA192X26.5L	TORA192X26.5R	55	.192 x 26.5"	15.47	Orange	7.6
TORA207X31L	TORA207X31R	65	.207 x 31"	19.06	Yellow	9.5
TORA207X28L	TORA207X28R	70	.207 x 28"	21.18	Yellow	8.1
TORA207X25.5L	TORA207X25.5R	80	.207 X25.5"	23.35	Yellow	7.9
TORA218X31L	TORA218X31R	85	.218 x 31"	24.99	White	10.1
TORA218X28L	TORA218X28R	95	.218 x 28"	27.78	White	8.9
TORA225X29L	TORA225X29R	105	.225 x 29"	30.81	Red	9.4
TORA234X32L	TORA234X32R	110	.234 x 32"	33.74	Brown	12.0
TORA243X32L	TORA243X32R	160	.243 X 32"	41.2	Green	10.9
TORA243X35L	TORA243X35R	125	.243 x 35"	37.54	Green	12
TORA250X39L	TORA250X39R	130	.250 x 39"	38.04	Gold	14.5
TORA262X40L	TORA262X40R	160	.262 X 42"	47.08	Blue	15.2
TORA262X43L	TORA262X43R	150	.262 X 43"	43.69	Blue	16.5
TORA262X45.5L	TORA262X45.5R	140	.262 x45.5"	41.22	Blue	17.2
TORA273X44L	TORA273X44R	175	.273 X 44"	51.71	Orange	17.5
TORA283X50L	TORA283X50R	180	.283 x 50"	54.05	Light Blue	20.7





2" ID PRE-CUT, FITTINGS INSTALLED - 7' HIGH DOORS - 4" DRUM

Part # Left	Part # Right	Lbs	Size	IPPT Rate	Color Code	Wt (Lbs)/Ea
TORB-080L	TORB-080R	80	.207 x 22.5"	23.60	Yellow	7.17
TORB-090L	TORB-090R	90	.207 x 20"	26.71	Yellow	6.37
TORB-100L	TORB-100R	100	.218 x 23"	30.28	White	7.80
TORB-110L	TORB-110R	110	.225 x 24.5"	32.61	Red	8.58
TORB-120L	TORB-120R	120	.234 x 27"	35.76	Brown	10
TORB-130L	TORB-130R	130	.234 x 25"	38.76	Brown	9.20
TORB-140L	TORB-140R	140	.243 x 28.5"	41.3	Green	10.87
TORB-150L	TORB-150R	150	.250 x 30"	44.4	Gold	11.78
TORB-160L	TORB-160R	160	.250 x 28"	47.72	Gold	11
TORB-170L	TORB-170R	170	.262 x 33.5"	50.34	Blue	13.89
TORB-180L	TORB-180R	180	.262 x 31.5"	53.67	Blue	13.06



2" ID UNCUT LONG LENGTHS*

Part # Left	Part # Right	Color Code	Wt (Lbs)/Ea
TORB207X24L	TORB207X24R	Yellow	7.67
TORB207X144L-NP	TORB207X144R-NP	Yellow	45.94
TORB218X144L-NP	TORB218X144R	White	48.79
TORB225X28L	TORB225X28R	Red	10.52
TORB225X144L-NP	TORB225X144R	Red	50.43
TORB234X32L	TORB234X32R	Brown	11.75
TORB234X144L-NP	TORB234X144R-NP	Brown	52.67
TORB243X144L-NP	TORB243X144R	Green	54.95
TORB250X32L	TORB250X32R	Gold	13.30
TORB250X36L	TORB250X36R	Gold	14.95
TORB250X144L-NP	TORB250X144R-NP	Gold	56.56
TORB262X37L	TORB262X37R	Blue	15.35
TORB262X144L-NP	TORB262X144R-NP	Blue	59.74
TORB273X144L-NP	TORB273X144R-NP	Orange	62.66



Torsion Spring Repair Blocks on pg 42.



*Uncut long lengths and other spring sizes not shown are available as custom order items. May be subject to a minimum order requirement and lead times. Call 800.431.3095 for details.



Fehr high cycle extension springs are manufactured from oil-tempered spring wire meeting ASTM A229 and are designed for a minimum of 25,000 cycles. Finished springs are coated for improved corrosion resistance and handling. Double loop ends are standard on all springs up to 180 Lbs with clip ends available on springs 100 Lbs through 400 Lbs.



25X42 FOR 7' DOORS WITH DOUBLE LOOP OR CLIP ENDS

Part # Double Loop	Part # Clipped End	Lbs	Color Code	Wt (Lbs)/Ea
EXT2542-040	-	40	Blue	1.75
EXT2542-050	-	50	Red	1.61
EXT2542-060	-	60	Brown	1.75
EXT2542-070	-	70	Orange	3.25
EXT2542-080	-	80	Gold	2.50
EXT2542-090	EXT2542-090CLIP	90	Light Blue	3.00
EXT2542-100	EXT2542-100CLIP	100	Tan	4.00
EXT2542-110	EXT2542-110CLIP	110	White	4.20
EXT2542-120	EXT2542-120CLIP	120	Green	4.10
EXT2542-130	EXT2542-130CLIP	130	Yellow	4.00
EXT2542-140	EXT2542-140CLIP	140	Blue	5.20
EXT2542-150	EXT2542-150CLIP	150	Red	5.00
EXT2542-160	EXT2542-160CLIP	160	Brown	6.40
EXT2542-170	EXT2542-170CLIP	170	Orange	6.20
EXT2542-180	EXT2542-180CLIP	180	Gold	6.00
	EXT2542-190CLIP	190	Light Blue	5.45
-	EXT2542-200CLIP	200	Tan	6.30
	EXT2542-210CLIP	210	White	8.10
-	EXT2542-220CLIP	220	Green	6.30
EXT2542-240	-	240	Blue	10.10
EXT2542-300	-	300	Tan	12.00
EXT2542-320	-	320	Green	13.00
EXT2542-330	-	330	Yellow	15.00
EXT2542-350	-	350	Red	15.20
EXT2542-360	-	360	Brown	15.36
EXT2542-400	-	400	White	15.18





30X48 FOR 8' DOORS WITH DOUBLE LOOP ENDS

Part #	Part # Clipped End	Lbs	Color Code	Wt (Lbs)/Ea
EXT3048-090		90	Light Blue	3.10
EXT3048-100		100	Tan	3.25
EXT3048-110	EXT3048-110CLIP	110	White	3.50
EXT3048-120	EXT3048-120CLIP	120	Green	3.25
EXT3048-130	-	130	Yellow	4.70
EXT3048-140	EXT3048-140CLIP	140	Blue	5.50
EXT3048-150	EXT3048-150CLIP	150	Red	5.60
EXT3048-160	-	160	Brown	6.25
EXT3048-170	EXT3048-170CLIP	170	Orange	6.60
EXT3048-180	EXT3048-180CLIP	180	Gold	7.40
-	EXT3048-190CLIP	190	Light Blue	7.50
-	EXT3048-220CLIP	220	Green	10.40
-	EXT3048-230CLIP	230	Yellow	11.45
-	EXT3048-260CLIP	260	Brown	13.30
-	EXT3048-270CLIP	270	Orange	14.70
-	EXT3048-290CLIP	290	Light Blue	15.30



SPRING RESTRAINT CABLES

Part #	Size	Description	Length	Loop	Color	Door Height	Wt/Pr
36901-120	3/32"	7x7	120"	Plain	Red	7'	0.48
36901-144	3/32"	7x7	144"	Plain	-	7'	0.48
36901-156	3/32"	7x7	156"	Plain	Brown	8'	0.50
36902-120	1/8"	7x7	120"	Plain	-	7'	0.66
36902-144	1/8"	7x7	144"	Plain	-	7'	0.96
36902-156	1/8"	7x7	156"	Plain	Yellow	8'	0.84



LOCK BAR SPRINGS

Part #	Description	Dealer Pack	Pieces	Wt (Lbs)/Ea
LBS360-DP	3" Lock Bar Spring	100	1	0.03

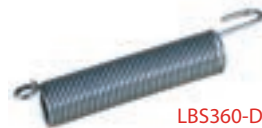

LBS360-DP



TSGA-UNI



Residential and Commercial Wire Gauges on pg 42.



EXTENSION SPRING MOUNTING ACCESSORIES

Part #	Description	Pack	Wt (Lbs)/Ea
EBB312X03-DP	5/16" x 3-1/2" Open Eyebolt	100	0.15
UB312X02-DP	5/16" x 2-1/4" U-Bolt with Nuts	100	0.12
EGSH187X1.5-DP	3/16" x 1-1/2" EG S-Hook	100	0.03
EGSH250X2.1-DP	1/4" x 2-1/4" EG S-Hook	100	0.06
ADJX100	3 Hole Cable Adjustment Clip	100	0.02



EGSH250X2.1-DP



EBB312X03-DP



UB312X02-DP



ADJX100



BUMPER SPRINGS

Part #	Description	Length	Pack	Wt (Lbs)
B610	Pusher Spring for 2" Track	9"	Ea	2.54
B610-3	Pusher Spring for 3" Track	9"	Ea	1.07
B620	Pusher (Left and Right Hand)	27"	Pr	8.3
B630	Leaf Type (Left and Right Hand)	-	Pr	5.0
B640	Pusher (Left and Right Hand)	15"	Pr	5.4



B630

Leaf type with safety strap



B620



B640



Universal Mini may be used on left or right sides



B610

Fehr spring fittings are die cast aluminum alloy and are color coded RED or BLACK. Each set includes a stationary bracket and a winding sleeve with set screws installed.



SPRING FITTINGS

Part #	Color Code	Bulk	Wt (Lbs)/Ea
CON175SBR	1-3/4"	160	0.20
CON175WS-RED	1-3/4"	80	0.40
CON175WS-BLACK	1-3/4"	80	0.40
CON200SBR	2"	160	0.18
CON200WS-RED	2"	80	0.40
CON200WS-BLACK	2"	80	0.40
CON258SBR	2-5/8"	120	0.33
CON258WS-RED	2-5/8"	60	0.60
CON258WS-BLACK	2-5/8"	60	0.60
CON375SBR	3-3/4"	48	0.70
CON375WS-RED	3-3/4"	24	1.05
CON375WS-BLACK	3-3/4"	24	1.05

Right wound springs use red color-coded winding sleeves



Left wound springs use black color-coded winding sleeves

- SBR=Stationary and WS=Winding. Call for details.



CON375WS-BLACK



CON375WS-RED



SHAFT COUPLERS & COLLARS

Part # Red	Description	Pack	Wt (Lbs)/Ea
CON10CS	Steel Coupler for 1" Shafts	1	0.68
TTCOUPLER	Steel Coupler for 1" Tube	1	0.39
SHAFTCOLLAR	Shaft Collar with Set Screw	1	0.22



SHAFTCOLLAR

For use on 1" solid shaft with keyway only



CON10CS

For use on 1" tubular shaft only



TTCOUPLER



Peg



STANDARD LIFT CABLE DRUMS

Part #	Maximums				Description	Mounting	Bulk	Wt (Lbs)/Pr
	Door Height	Door Weight	Cable	Diameter				
CON400-8	8'-1"	530	1/8"	4.8"	Standard Lift	1" Tube or Solid Shaft with Key	60	2.2
CON400-12	12'-1"	750	5/32"	5.0"	Standard Lift	1" Tube or Solid Shaft with Key	40	4.2
CON5250-18	19'-6"	1,500	3/16"	6.0"	Standard Lift	1" Solid Shaft with Key		5.2



CON400-8



CON400-12



CON5250-18



HIGH LIFT CABLE DRUMS

Part #	Maximums				Description	Mounting	Bulk	Wt (Lbs)/Pr
	Door Height	Door Weight	Cable	Diameter				
CON400-54	10' + High Lift	550	5/32"	6.0"	54" High Lift	1" Solid Shaft with Key	36	7.8
CON5250-54	15' + High Lift	1,000	3/16"	7.5"	54" High Lift	1" Solid Shaft with Key	12	9.6
CON5750-120	12' + High Lift	1,000	3/16"	9.5"	120" High Lift	1" Solid Shaft with Key	8	10.0



CON400-54



CON5250-54



CON5750-120



ROYAL UNIFLEX™ GARAGE DOOR THERMOSTOP®



THE INDUSTRY'S MOST ADVANCED GARAGE DOOR STOP. SUPERIOR DESIGN AND QUALITY PROVIDES ENHANCED PERFORMANCE AND EASE OF INSTALLATION. ITS DESIGN ELIMINATES FLEX DISTORTION DURING SHIPMENT AND STORAGE.

- Flex mount design delivers the combined benefits of both side and top flex profiles.
- Flex is attached to both top and side surfaces increasing adhesion by 75%.
- Angled corner allows stacking without flex deformation, improving both packaging and storage.
- Packaging is designed to prevent product spill.

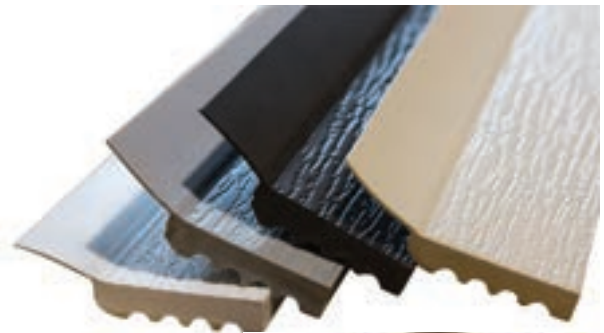

75% increased flex adhesion



UNIFLEX™ - (01 BRIGHT WHITE P78)*

Size	Part # Undrilled	Pcs/Ctn	Wt (lbs)/Ctn
7'	WS214901-07W	15	23.60
8'	WS214901-08W	15	26.97
9'	WS214901-09W	15	30.34
10'	WS214901-10W	15	33.72
12'	WS214901-12W	15	40.46
14'	WS214901-14W	15	47.20
16'	WS214901-16W	15	53.95
18'	WS214901-18W	15	60.69

* Chart on left shows part numbers for 01 Bright White (P78). Use as a guide to format all part numbers.

WS214901-07WP

The 7th and 8th characters of our code designate the color, **01** = Bright White (P78). Use the color chart on the next page to see the complete list of color codes.

Characters 10 and 11 designate the length, **07** = 7 Feet.



ROYAL UNIFLEX™ COLOR PALETTE

ROYAL UNIFLEX™ Garage Door Thermostop® is available in 32 colors. Predrilling and packaging options are available to meet specific needs.

Ronan™ cutter & Accessories on pg 41.



01 BRIGHT WHITE (P78)	02 ALMOND (P48)	03 SANDSTONE (P408)	04 DARK BROWN (P5)	05 HUNTER GREEN (P501)	06 GRAY (P509)	07 WICKER (P443)
08 DESERT TAN (P574)	09 BRONZE (P401)	10 LIGHT ALMOND (P547)	11 CHOC BROWN (P446)	12 WHITE (P44)	13 RED BROWN (P31)	14 CHESTNUT BRN (P72)
15 MEDIUM OAK (P599)	16 DARK OAK (P603)	17 MAHOGANY RSR* (P604)	18 WALNUT RSR* (P615)	19 GLACIER WHITE (P626)	20 TERRA BRONZE (P607)	21 CHERRY RSR* (P620)
22 SILVER GRAY (P434)	23 CLAY/TAUPE (P477)	24 CREAM (P633)	25 COFFEE RSR* (P628)	26 MOCHA BROWN RSR* (P627)	27 BLACK (P637)	28 DARK OAK RSR* (P631)
29 DARK BROWN RSR* (P637)	30 CHOC BROWN RSR* (P630)	31 DL BROWN (P613)	32 SOFT BLACK RSR* (P641)			

* RSR ROYAL SOLAR REFLECTIVE™ colors have specialized pigment formulations and high performance heat modifiers to achieve improved performance.

- Sixteen stock colors: P44 WHITE, P48 ALMOND, P78 BRT WHITE, P5 DARK BROWN, P408 SANTONE, P509 GRAY, P501 HUNTER GREEN, P607 BRONZE, P574 DESERT TAN, P446 CHOCOLATE BROWN, P599 MED. OAK, P603 DARK OAK, P443 WICKER, P615 WALNUT P547 LIGHT ALMOND AND P637 BLACK.
- Sixteen custom order colors. Minimum order quantities apply.
- Call 800.431.3095 for upgraded packing and custom color stocking options.



ROYAL UNIFLEX™ WIDE STOP - (3-1/4" NEW PROFILE)

Part #	Color #	Width	Flex	Pcs/Ctn	Wt (Lbs)/Ctn
WS2591N-16W	Bright White	3-1/4"	1-1/4"	10	69.5
WS2591N-16A	Almond	3-1/4"	1-1/4"	10	69.5
WS2591N-16S	Sandstone	3-1/4"	1-1/4"	10	69.5
WS2591N-16B	Dark Brown	3-1/4"	1-1/4"	10	69.5
WS2591N-18W	Bright White	3-1/4"	1-1/4"	10	69.5
WS2591N-18S	Sandstone	3-1/4"	1-1/4"	10	69.5
WS2591N-18B	Dark Brown	3-1/4"	1-1/4"	10	69.5



INTEPLAST GROUP[®]
Building Products



WOODGRAIN JAMB SEAL - 7/16

Part #	Color #	Width	Length	Pcs/Ctn	Wt (Lbs)/Ctn
WS236723-14BL	True Black (912)	2"	14'	15	46.27
WS236912-16BL	True Black (912)	2"	16'	15	52.88
WS236912-18BL	True Black (912)	2"	18'	15	68.00

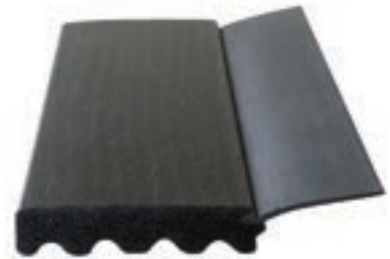

Fehr stocks many styles and lengths of Advanced Plastic Corp. products. Those that we do not stock are available as factory direct. Call 800.431.3095 for details.



RIDGID DOOR STOP - (DS-200 HOLLOW BACK)

Part #	Color	Width	Flex	Pcs/Ctn	Ft/Ctn	Wt (Lbs)/Ctn
DS200-16W	White	2"	1"	15	240	54
DS200-16A	Almond	2"	1"	15	240	54
DS200-16B	Brown	2"	1"	15	240	54
DS200-16S	Sandstone	2"	1"	15	240	54
DS200-16GN	Green	2"	1"	15	240	54
DS200-16GY	Gray	2"	1"	15	240	54
DS200-16DT	Desert Tan	2"	1"	15	240	54
DS200-16BL	Black	2"	1"	15	240	54
DS200-16CB	Chocolate Brown	2"	1"	15	240	54
DS200-16TB	Terratone Bronze	2"	1"	15	240	54

Factory direct
in lengths
from 7'-18'



DS200-16BL



RIDGID DOOR STOP - (DS-258 HOLLOW BACK)

Part #	Color	Width	Flex	Pcs/Ctn	Ft/Ctn	Wt (Lbs)/Ctn
DS258-16W	White	2-5/8"	1"	14	240	65
DS258-16A	Almond	2-5/8"	1"	14	240	65
DS258-16B	Brown	2-5/8"	1"	14	240	65
DS258-16S	Sandstone	2-5/8"	1"	14	240	65
DS258-16GN	Green	2-5/8"	1"	14	240	65
DS258-16GY	Gray	2-5/8"	1"	14	240	65
DS258-16DT	Desert Tan	2-5/8"	1"	14	240	65
*DS258-16BL	Black	2-5/8"	1"	14	240	65
DS258-16CB	Chocolate Brown	2-5/8"	1"	14	240	65
DS258-16TB	Terratone Bronze	2-5/8"	1"	14	240	65

Factory direct in lengths from 7'-18'



DS258-16GN

*Black available in 9', 16', 18' only.



ROLLED DOOR STOP - (RS 200)

Part #	Color	Flex	Ft/Ctn	Wt (Lbs)/Ctn
RDS-200-W	White	1-1/4"	150'	40
RDS-200-A	Almond	1-1/4"	150'	40
RDS-200-S	Sandstone	1-1/4"	150'	40
RDS-200-B	Brown	1-1/4"	150'	40
RDS-200-BL	Black	1-1/4"	150'	40
RDS-200-GY	Gray	1-1/4"	150'	40
RDS-200-GN	Green	1-1/4"	150'	40
RDS-200-DT	Desert Tan	1-1/4"	150'	40
RDS200-CB	Chocolate Brown	1-1/4"	150'	40
RDS200-TB	Terratone Bronze	1-1/4"	150'	40

Easy to install on straight, gothic and arched openings



RDS-200-GY



ROLLING STEEL GUIDE SEAL

Part #	Color	Length	Guide Thickness	Pcs/Ctn	Wt (Lbs)/Ctn
GS20-09	Gray	9'-6"	1/8"	25	30.9
GS20-16	Gray	16'-6"	1/8"	25	53.8
GS38-14.5	Gray	8'-6"	1/4"	20	46.5
GS38-16.5	Gray	16'-6"	1/4"	20	52.8



GS20

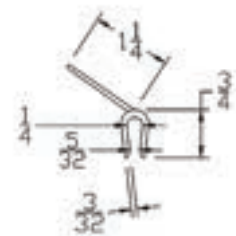



REVERSE ANGLE SEAL - (JS-02)

Part #	Color	Flex	Ft/Ctn	Wt (Lbs)/Ctn
REVANGLE-W	White	1-1/4"	200'	22
REVANGLE-A	Almond	1-1/4"	200'	22
REVANGLE-B	Brown	1-1/4"	200'	22
REVANGLE-BL	Black	1-1/4"	200'	22
REVANGLE-G	Gray	1-1/4"	200'	22
REVANGLE-S	Sandstone	1-1/4"	200'	22
REVANGLE-CB	Chocolate Brown	1-1/4"	200'	22
REVANGLE-TB	Terratone Bronze	1-1/4"	200'	22

Available in six popular colors, clips directly to angle

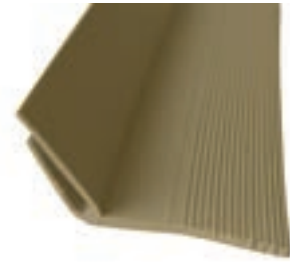

REVANGLE-A

Can be installed with flex visible or behind jamb

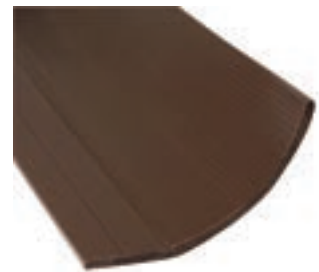

RS175-B



STUCCO JAMB SEAL - (RS 175)

Part #	Color	Flex	Ft/Ctn	Wt (Lbs)/Ctn
RS175-W	White	1-3/4"	300'	37
RS175-A	Almond	1-3/4"	300'	37
RS175-S	Sandstone	1-3/4"	300'	37
RS175-B	Brown	1-3/4"	300'	37
RS175-BL	Black	1-3/4"	300'	37
RS175-GY	Gray	1-3/4"	300'	37
RS175-CB	Chocolate Brown	1-3/4"	300'	37



TS14

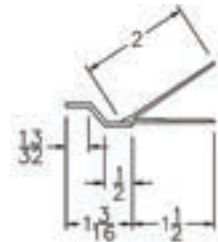

TOP SEAL

Part #	Color	Flex	Ft/Ctn	Wt (Lbs)/Ctn
TS14	Black	2" and 1-1/2"	300'	51
TS15	Black	1-3/4"	200'	20
TS200	Black	2"	300'	15
TS300	Black	3"	100'	17



TS15



TS200

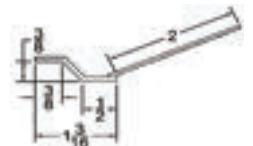

TOP CAP SEAL

Part #	Color	Length	Flex	Pcs/Ctn	Wt (Lbs)/Ctn
TC138-09	Black	9'	1-3/4"	12	39
TC138-16	Black	16'	1-3/4"	12	54
TC200-09	Black	9'	2"	8	23.4
TC200-16	Black	16'	3"	8	41.6

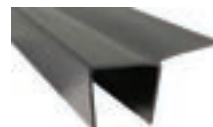

TC138

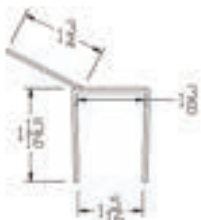



HEADER & HOOD BAFFLES - GRAY

Part #	Description	Pcs/Ctn	Ft/Ctn	Wt (Lbs)/Ctn
HS-22S-48	Rolling Steel Header	6	48'	20.8
HS-22S-96	Rolling Steel Header	6	96'	41.6
HS-62S-75	Rolling Steel Header	1	75'	31.5
HB-12	Hood Baffle	1	150'	48

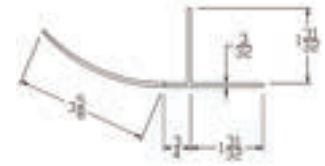

HS-22S



MW-375

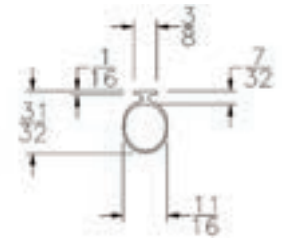

T MINI WAREHOUSE BOTTOM BULB - 3/8"

Part #	Color	T-Width	Ft/Ctn	Wt (Lbs)/Ctn
MW-375	Gray	3/8"	200'	18

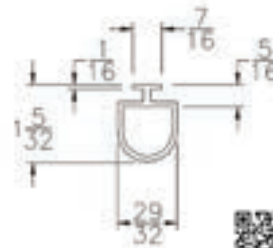

WD-716



T MINI WAREHOUSE BOTTOM BULB - 7/16

Part #	Color	T-Width	Ft/Ctn	Wt (Lbs)/Ctn
WD-716	Gray	7/16"	150'	23

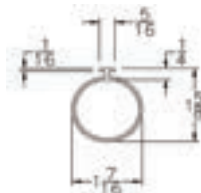

TB-150



T-BULB BOTTOM SEAL

Part #	Color	Width	Ft/Ctn	Wt (Lbs)/Ctn
TB-050	Gray	1/2"	100'	14
TB-100	Gray	1"	100'	38
TB-150	Gray	1-1/2"	150'	52



P-BULB BOTTOM SEAL FOR WINDSOR

Part #	Color	Width	Ft/Ctn	Wt (Lbs)/Ctn
PB-100	Black	1-1/8"	200	47

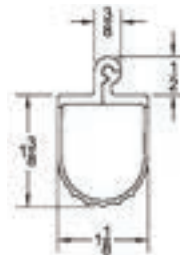

PB-100



SNAP-ON MINI WAREHOUSE BOTTOM SEAL

Part #	Color	Width	Length	Pcs/Ctn	Wt (Lbs)/Ctn
SNP-001-04	Gray	15/16"	4'	20	9
SNP-001-09	Gray	15/16"	9'	20	21

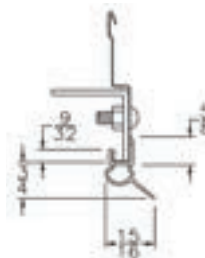

SNP-001-04





ROLLING STEEL BOTTOM SEAL

Part #	Color	Width	Ft/Ctn	Wt (Lbs)/Ctn
RB21F-BL	Black	1-1/2"	150'	36
RB21F-GY	Gray	1-1/2"	150'	36
RB21F-YEL	Yellow	1-1/2"	150'	36

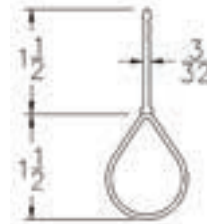

RB21F-YEL



"O" BOTTOM SEAL

Part #	Color	Width	Ft/Ctn	Wt (Lbs)/Ctn
CLO400-125	Black	4"	125	22.5

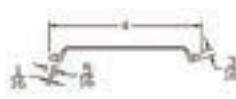

CLO400-125

Also available in shiplap and tongue & groove models



WS138-9



TRIPLE CONTACT BOTTOM SEAL - BLACK

Part #	Model #	Style	Width	Length	Pcs/Ctn	Wt (Lbs)/Ctn
WS138-09	CP-05	Std	1-3/8"	9'	12	29
WS138-16	CP-05	Std	1-3/8"	16'	12	51
WS200-09	CP-10	Std	2"	9'	8	27
WS200-16	CP-10	Std	2"	16'	8	47

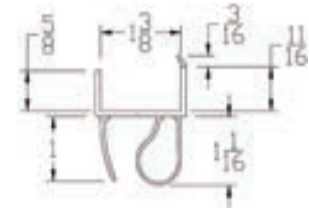

CP-05

- Also available in other sizes as dropship orders.



TRIPLE CONTACT OPEN FACE BOTTOM SEAL - BLACK

Part #	Model #	Style	Width	Length	Pcs/Ctn	Wt (Lbs)/Ctn
WS138OFB-8	CP-138OFB	Open Face	1-3/8"	8'	15	32
WS138OFB-16	CP-138OFB	Open Face	1-3/8"	16'	15	60
WS200OFB-9.2	CP-07OF	Open Face	2"	9'-2"	10	29
WS200OFB-16.2	CP-07OF	Open Face	2"	16'-2"	10	52

All CP models are available in 8', 9', 10', 12', 14' and 16' lengths

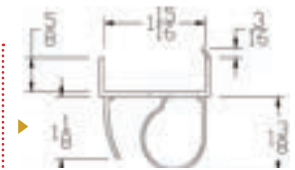

CP-10

- Dropship only.



TRIPLE CONTACT LONG LEG BOTTOM SEAL - BLACK

Part #	Model #	Style	Width	Length	Pcs/Ctn	Wt (Lbs)/Ctn
WS200-LL-9.2	CP-07	Long Leg	2"	9'-2"	6	19
WS200-LL-16.2	CP-07	Long Leg	2"	16'-2"	6	38

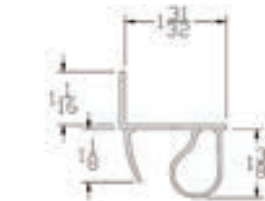

CP-07OF

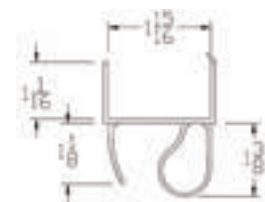

CP-07

- Other sizes and lengths are available as dropship orders.

AR175 and AR200 are shown with FR-375 installed (sold separately)

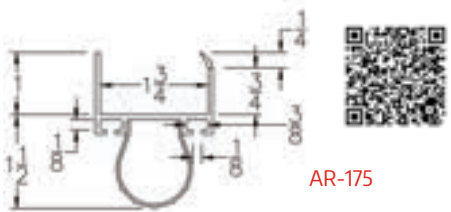

AR-175



DOUBLE ASTRAGAL BOTTOM SEAL - BLACK

Part #	Model #	Style	Width	Length	Pcs/Ctn	Wt (lbs)/Ctn
AR-138-09	AR-138	Std	1-3/8"	9'	8	23
AR-138-16	AR-138	Std	1-3/8"	16'	8	41
AR-175-09	AR-175	Std	1-3/4"	9'	8	26
AR-175-16	AR-175	Std	1-3/4"	16'	8	53
AR-02-09	AR-02	Std	2"	9'	6	17
AR-02-16	AR-02	Std	2"	16'	6	35
AR-03-09	AR-03	Std	3"	9'	4	27
AR-03-16	AR-03	Std	3"	16'	4	47



DOUBLE ASTRAGAL LONG LEG BOTTOM SEAL - BLACK

Part #	Model #	Style	Width	Length	Pcs/Ctn	Wt (Lbs)Ctn
ARL138-09	ARL-138	Long Leg	1-3/8"	9'	6	27
ARL138-16	ARL-138	Long Leg	1-3/8"	16'	6	60
ARL200-09	ARL-200	Long Leg	2"	9'	4	24
ARL200-16	ARL-200	Long Leg	2"	16'	4	43

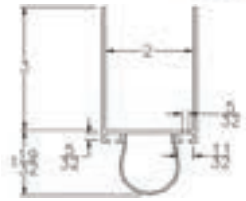

ARL200-16



UNISIZE BOTTOM SEAL - BLACK

Part #	Model #	Style	Width	Length	Pcs/Ctn	Wt (Lbs)/Ctn
UNI-100-8.2	UNI-100	Std	3/4-2"	8'	15	32
UNI-100-9.2	UNI-100	Std	3/4-2"	9'	15	36
UNI-100-10.2	UNI-100	Std	3/4-2"	10'	15	40
UNI-100-12.2	UNI-100	Std	3/4-2"	12'	15	44
UNI-100-14.2	UNI-100	Std	3/4-2"	14'	15	46
UNI-100-16.2	UNI-100	Std	3/4-2"	16'	15	64
UNI-100-18.2	UNI-100	Std	3/4-2"	18'	15	73

Designed to fit a variety of door thicknesses



UNI-100



UNISIZE OPEN FACE BOTTOM SEAL - BLACK

Part #	Model #	Style	Width	Length	Pcs/Ctn	Wt (Lbs)/Ctn
UNI-100-16.2OF	UNI-100 OF	Open Face	3/4-2"	16'-2"	15	17
UNI-100-18.2OF	UNI-100 OF	Open Face	3/4-2"	18'-2"	15	35
UNI-300-16.2OF	UNI-300 OF	Open Face	2"-3-1/2"	16'-2"	15	24
UNI-300-18.2OF	UNI-300 OF	Open Face	2"-3-1/2"	18'-2"	15	43

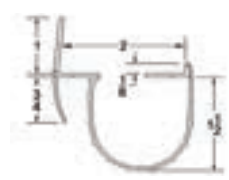

UNI-100-16.2OF



EPDM BOTTOM SEAL

Part #	Color	Width	Ft/Ctn	Wt (Lbs)/Ctn
WS-BOTSEAL-200	Black	1-3/8"	200'	20.5
WS-HARD-BOTSEAL	Black	1-3/8"	100'	27
WS-HARDBOTSEAL-1.75	Black	1-3/4"	100'	31

EDPM hard and soft styles may be used on wood sections



WS-BOTSEAL



ASTRAGAL

Part #	Description	Color	Width	Ft/Ctn	Wt (Lbs)/Ctn
WD325X400	Resi. T-Astragal	Black	3-1/4"	400'	50
FR-375	T-Astragal	Black	3-3/4"	400'	51
FR-375GY	T-Astragal	Gray	3-3/4"	400'	51
FR-475	T-Astragal	Black	4-3/4"	200'	32
FR-600	T-Astragal	Black	3"	200'	40
FRB-300	Bead Astragal	Black	3"	500'	69
FRB-400	Bead Astragal	Black	4"	400'	58
FRB-600	Bead Astragal	Black	6"	300'	61
FRX-375	X-Treme Temp T	Black	3-3/4"	200'	27
FRX-475	X-Treme Temp T	Black	4-3/4"	200'	31
FRX-600	X-Treme Temp T	Black	6"	200'	33

T-Style bottom astragal is available in standard and X-Treme flexible to -50°



FR-375

Bead style astragal for retainers with round slots

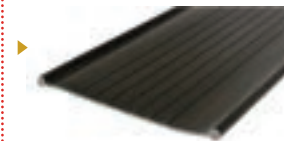

FRB-400



RETAINERS - BLACK

Part #	Model #	Style	Width	Length	Pcs/Ctn	Wt (Lbs)/Ctn
UR138-09	UR-138	Universal	1-3/8"	9'	25	31
UR138-16	UR-138	Universal	1-3/8"	16'	25	55
UR175-09	UR-175	Universal	1-3/4"	9'	20	28
UR175-16	UR-175	Universal	1-3/4"	16'	20	53.5
UR200-16	UR-200	Universal	1-3/4"	16'-2"	15	58
URS-100-09	URS-100	Universal	1"	9'	25	30
URF138-16	URF-138	Astragal	1-3/8"	16'	30	49
URF150-16	URF-150	Astragal	1-1/2"	16'	30	53
URF175-16	URF-175	Astragal	1-3/4"	16'	30	54
URF200-16	URF-200	Astragal	2"	16'-2"	25	56

UR Universal retainer is shown with FR-375 installed (sold separately)

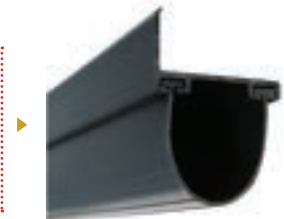

URF retainers are available in 8', 9', 10', 12', 16' and 18' lengths



UR200-16



THRESHOLD

Part #	Color	Width	Ft/Ctn	Tubes of Adhesive	Wt (Lbs)/Ctn
WS-THRESH-100	Black	3"	100'	10	51.5
WS-THRESH-100GY	Gray	3"	100'	10	51.5
WS-THRESH-10	Black	3"	10'	1	5.2
WS-THRESH-16	Black	3"	16'	2	8.3
WS-THRESH-20	Black	3"	20	2	10.4
WS-ADHESIVE	Clear	-	10.2 Oz	12	7.7

All kits include appropriate amount of adhesive



WS-THRESH-100



RODENT CONTROL - XCLUDER

Part #	Description	Style	Width	Length	Pcs/Ctn	Wt (Lbs)/Ctn
XC-162706	Fill Fabric	-	4"	10'	1	2
XC-162707	Fill Fabric	-	4"	10'	5	6.5
XC-162731	Fill Fabric	Kit	4"	10'	1	2.2
XC-162940	Shields	Stainless	1"	8"	2	0.1



XC-162731

Kit includes shears and gloves



XC-162707



Installed in FR-375 "T" Style Bottomseal



SPRING FILLER

Part #	Color	Width	Length	Pcs/Bundle	Wt (Lbs)/Pcs
*PSF-425-12	Black	4-1/4"	12	150	10

*Minimum order 150pcs.

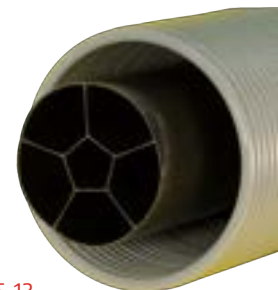

PSF-425-12



TRUCK DOOR ASSEMBLIES - 1/8" 7 X 19 STAINLESS AIRCRAFT CABLE

Part #	Size	Fits	Length	Loop	Color	Wt/Pr
37601-96	1/8"	1/4" Clevis Pin	96"	Spool Eye	Brown	0.55
37601-110	1/8"	1/4" Clevis Pin	110"	Spool Eye	Red	0.60
37601-115	1/8"	1/4" Clevis Pin	115"	Spool Eye	Blue	0.61
37601-120	1/8"	1/4" Clevis Pin	120"	Spool Eye	Orange	0.62
37601-125	1/8"	1/4" Clevis Pin	125"	Spool Eye	Green	0.63
37601-130	1/8"	1/4" Clevis Pin	130"	Spool Eye	Yellow	0.64
37701-105	1/8"	5/16" U-Bolt	105"	Bev Spool	Yellow	0.58
37701-110	1/8"	5/16" U-Bolt	110"	Bev Spool	Brown	0.59
37701-115	1/8"	5/16" U-Bolt	115"	Bev Spool	Green	0.60
37701-125	1/8"	5/16" U-Bolt	125"	Bev Spool	White	0.66
37701-130	1/8"	5/16" U-Bolt	130"	Bev Spool	Orange	0.68
37801-105	1/8"	Roller Shaft	105"	Large Spool	Yellow	0.54
37801-110	1/8"	Roller Shaft	110"	Large Spool	Brown	0.60
37801-115	1/8"	Roller Shaft	115"	Large Spool	Green	0.62
37801-125	1/8"	Roller Shaft	125"	Large Spool	Red	0.66
37801-130	1/8"	Roller Shaft	130"	Large Spool	Blue	0.68



37601-115



37701-110



37801-115



TRUCK DOOR ASSEMBLIES - 1/8" 7 X 19 GALVANIZED AIRCRAFT CABLE

Part #	Size	Fits	Length	Loop	Color	Wt/Pr
37001-105	1/8"	1/4" Clevis Pin	105"	Spool Eye	Brown	0.60
37001-110	1/8"	1/4" Clevis Pin	110"	Spool Eye	Gray	0.61
37001-115	1/8"	1/4" Clevis Pin	115"	Spool Eye	Black	0.62
37001-120	1/8"	1/4" Clevis Pin	120"	Spool Eye	Orange	0.63
37001-125	1/8"	1/4" Clevis Pin	125"	Spool Eye	Blue	0.64
37001-130	1/8"	1/4" Clevis Pin	130"	Spool Eye	Green	0.65



37001-110





TRUCK DOOR ASSEMBLIES - 1/8" 7 X 19 GALVANIZED AIRCRAFT CABLE

Part #	Size	Fits	Length	Loop	Color	Wt/Pr
37101-97	1/8"	5/16" U-Bolt	97"	Bev Spool	Green	0.51
37101-105	1/8"	5/16" U-Bolt	105"	Bev Spool	-	0.58
37101-110	1/8"	5/16" U-Bolt	110"	Bev Spool	Brown	0.59
37101-115	1/8"	5/16" U-Bolt	115"	Bev Spool	Green	0.60
37101-125	1/8"	5/16" U-Bolt	125"	Bev Spool	White	0.66
37101-130	1/8"	5/16" U-Bolt	130"	Bev Spool	Orange	0.68
37201-105	1/8"	Roller Shaft	105"	Large Spool	Yellow	0.54
37201-110	1/8"	Roller Shaft	110"	Large Spool	Brown	0.60
37201-115	1/8"	Roller Shaft	115"	Large Spool	Green	0.62
37201-125	1/8"	Roller Shaft	125"	Large Spool	Red	0.66
37201-130	1/8"	Roller Shaft	130"	Large Spool	White	0.68



37101-130



37201-115



TRUCK DOOR HINGES, HANDLES & BRACKETS

Part #	Description	Finish	Pack	Wt (Lbs)/Ea
T61196	Roll-up Truck Door Center Hinge (61196 style)	Powder Coat	1	0.30
T69433	Roll-up Truck Door Adjustable Top Fixture (69433 style)	Powder Coat	1	0.66
T61352	Roll-up Truck Door Bottom Fixture (61352 Style)	Powder Coat	1	0.51
T61401	Roll-up Truck Door Heavy Duty Lift Handle (61401 Style)	Powder Coat	1	0.50
T61204	Roll-up Truck Door Cable Anchor Bracket (61204 style)	Powder Coat	1	0.08



T69433



*Fehr truck door hardware is powder coated for a thicker and more durable finish. Powder coating provides a finish with excellent weatherability, superb hardness, increased humidity resistance, and great protection against UV rays.



T61401



T61196



David



T61352



T61204





ROLL22



Jose and Kerry



TRUCK DOOR ROLLERS

Part #	Description	Stem Length	Cycles-9' door 125 lb load	Bulk	Dealer Pack	Wt (Lbs)/Ea
ROLL22	1" - 7 Ball Steel	2-3/4" Zinc	30,000	200	25	0.20
ROLL23	2" -13 Ball Nylon	2-3/4" Zinc	30,000	200	25	0.25
ROLL24	2" -10 Ball Steel	2-3/4" Zinc	15,000	-	50	0.29



ROLL23



ROLL24



STEP BOLTS

Part #	Description	Finish	Type	Pack	Wt (Lbs)/Ea
C6457-100	1/4" x 1-1/4"	Zinc Magni-Coat	Rib Neck	100	2.50
C6458-100	1/4" x 1-1/2"	Zinc Magni-Coat	Rib Neck	100	2.81



C6457-100



DRUMS

Part #	Description	Capacity	Type	Pack	Wt (Lbs)/Ea
CON300-C	3" Cable Drum	130"	Curbside	1	0.98
CON300-R	3" Cable Drum	130"	Roadside	1	0.98



CON300



TYPE 316 Cable Railing Hardware



STAINLESS STEEL CABLE

Part #	Diameter	Type	Breaking Strength (Lbs)	Wt (Lbs)/1,000 Ft
2T19156	5/32"	1 x 19	2,800	60

- Standard reels available in: 100', 250', 500', 1,000', 5,000'.



CABLE GUARD

Part #	Length	Cable Size	Maximum Angle	Wt (Lbs)/Ea
C0915-0438	1.5"	1/8" and 5/32"	90°	0.09



C0915-0438



2T19156



RAILEASY™ REPLACEMENT CONES

Part #	Pcs/Bag	Wt (Lbs)/Ea
S0980-0002-4	4	0.08



C0980-0002-4



RAILEASY™ REPLACEMENT WEDGES

Part #	Pcs/Bag	Wt (Lbs)/Ea
S0980-0001-10	10	0.10



C0980-0001-10



RAILEASY™ DRILLING TEMPLATE

Part #	Predrilled Spacing	Wt (Lbs)/Ea
S0988-1000	3"	0.19



C0988-1000



RAILEASY™ TENSIONER - FLAT

Part #	Cable Size	Length	Base Diameter	Adjustment	Wt (Lbs)/Ea
S0981-0004	5/32"	5-3/8"	1-1/2"	1-3/8"	0.16

- Slotted base allows for 45° cable angle.



S0981-0004



Victor



RAILEASY™ SWIVEL END - FLAT

Scan and view full
Cable Railing Catalog



Part #	Cable Size	Length	Base Diameter	Wt (Lbs)/Ea
S0981-S004	5/32"	2-5/8"	1-1/2"	0.12

- Slotted base allows for 45° cable angle.



S0981-S004



RAILEASY™ STUD ASSEMBLY

Part #	Cable Size	Stud Length	Stud Diameter	Thread Length	Wt (Lbs)/Ea
S0980-0004X2	5/32"	4-1/2"	1/4"	3"	0.25



S0980-0004X2



S0980-R004X2



RAILEASY™ LAG STUD

Part #	Thread Direction	Cable Size	Stud Length	Lag Diameter	Wt (Lbs)/Ea
S0980-R004X2	Right	5/32"	2-1/4"	9/32"	0.17

- Visit our website for additional railing hardware OR Call for more information.



CUSTOM CABLE & CHAIN ASSEMBLIES

From small batch specialized assemblies to large run OEM requirements, Fehr Bros. has the manufacturing capabilities to meet customers' specific needs.



DOOR LIFT CABLES

- Plain and Thimbled Loop Extension Cables
- Torsion Lift Cables with Stop or Floating Stop
- Spring Restraint Cables, Door Lock Cables



LIGHTING RESTRAINT

- Powder White, Powder Black, GAC and SSAC
- 1/4" or 5/16" Spring Hooks
- 18", 30", 48" or Custom



WINCH ASSEMBLIES

- 7 x 19 GAC/SSAC, Wire Rope
- Clevis Slip Hook with Latch, Eye Hoist Hook with Latch
- Sizes 3/16"-1/2"



SLINGS

- Tagged and Rated
- 3/8"-7/8" IWRC, GAC, or SSAC
- Plain Loop or Thimbled Loop



PUMP LIFTING

- Custom Sizes 1/4"- 1" SSPC Chain
- Corresponding Key Hook and Lift Assembly
- Stainless Steel with Copper Fittings



CUSTOM SOLUTIONS

- Private Labeling
- Custom Packaging
- Chain Assemblies
- Hardware Kits
- Dealer Display Packs
- Bar Coding



Aluminum Swage Fittings . . .	20, 21	Locks	25	Spring Hooks	60, 61
Anchor Bolts	75	Sleeves & Stops	20, 21, 22	Swivels	57
Anchor Shackles	65, 66, 67	Thimbles	22, 23, 20	Split Rings	59
Assemblies		Wire Rope Clips	15, 16	Copper Swage Fittings	23, 24
Cable & Wire Rope	18	Cable Meter	41	Custom Assemblies	
Extension Door	99	Cable Puller	41	Cable	124
Lighting Restraint Cables	18	Cable Railing Hardware	122, 123	Chain	124
Torsion Doors	98	Chain		Cutting Tools	
Beam Clamps	33	Alloy	29	Cable	35
Bearing Plates		Binder	32	Chain	35
Bearing	95	Cutting Tool	35, 36, 37	Deck Chain	28
Decorator Angles	94	Slings	34	Double Clevis	59
End	94	Deck Chain	29	Earth Anchors	51
Spring Anchor	95	Double Loop	30	Eyebolts	
Binder Chains	32	G43 High Test	27	Drop Forged	69
Blocks		G70 Transport	29	Machinery Plain	70
Galvanized	47	G80 Alloy	29	Machinery Shoulder	70
Stainless Steel	46	Grab Link Assemblies	34	Metric Shoulder	70
Yarding	47	Machine Chain	30	Washers	71
Brackets		Mooring Chain	28	Eye Lag Screws	71
Bottom	89	Passing Link	30	Extension Cords	41
Clevis	90	G30 Proof Coil	27	Fasteners	
Jamb	90	Sash	31	Anchor Bolts	75
Lift Handles	90	Stainless Steel	28	Carriage Bolts	73
Low Headroom	87, 88, 89	Single Jack	31	Drill and Tap Screws	72
Quick Close	88	Straight Link	30	Eyebolt Washers	71
Reinforcement	88	Chain Hoists	97	Eye Lag Screws	71
Step Plates	90	Clips		Flat Washers	74
Top	87	Adjustment	25	Flange Nuts	75
Braided Synthetic Cord	42	Wire Rope	15, 16	Hex Head Bolts	73
Cable		Coir Twine	41	Hex Nuts	74
Assemblies	19	Cones & Drums	108	Hex Washer Head Lags	73
Black Coated Galvanized	9	Connecting Hardware		J-Bolts	71
Hot Dip Galvanized	6, 7	Cold Shuts	58	J-Lag Hooks	71
Guy Strand	17	Connecting Links	58	Kep Nuts	74
Left Lay	11	Double Clevis	59	Lag & SMS Screws	72
Nylon Coated	8	Hammerlocks	33	Loop Nuts	72
Stainless Steel	9, 10, 124	Lap Links	58	Maze Nails	76
Vinyl Coated	8	Masterlinks	33	Sheet Metal Screws	72, 73
ZN-AL Cable	11	Pear Links	56	Tap Bolts	73
Cable Accessories		Quick Links	56	Track Bolts	74
Adjustment Clips	25	S-Hooks	59	Garage Door Hardware	81
Kwik-Loc™	25	Snap Hooks	60	Gripple Cable Adjusters	25

Gripple Torque Tensioning Tool.....	25	Inside Handles	92	Chain	66
Guy Strand & Hardware		Keys	93	Commercial Grade.....	67
Dead Ends	18	Latches & Strikers	92	Domestic	65, 66
End Sleeves.....	18	Lock Bars	93	Duty Rated	65, 66
Guy Strand Common Grade ...	17	Sets	91, 92, 94	Safety	67
Guy Strand EHS.....	17	Side	91	Stainless Steel Bow.....	68
Splices	17	Lock Bar Springs	105	Stainless Steel Straight D....	68
Tensioners	17	Lubricants		Stainless Steel Wide D.....	68
Hammerlocks	33	Lubriplate.....	78	Sheaves	
Hand Cleaner Towels	78	Spray Lube	77, 78	Cast	96
Hand Winches	50	Penetrating Oil.....	77, 78	Forks	96
Helix Anchors	51	Food Grade	77, 78	Kit.....	97
Hinges		Slipit Gel	80	Stamped.....	96
Commercial & Industrial	86	Slipit Silicone Free	80	Stainless Steel.....	46
Half Hinges	87	Slipit Sliding Compound ..	79, 80	Slings	
Narrow Design	87	Slipit Spray.....	80	Cable & Wire Rope	19, 126
Residential.....	86	Maze Nails		Chain	34, 126
Hops Clips & Tool.....	41	Galvanized	76	Tuflex® Round Slings.....	43, 44
Hooks		Stainless Steel.....	76	Steel Flex Round Slings.....	44
Alloy.....	64	Perforated Angle		Tuff-Edge®III Web Slings	45
Grab.....	63, 64	Galvanized	85	Slipit	
Hoist	64	Painted	85	Gel	80
Slip	62	Polyester Slings	43, 44, 45	Lubricant	79, 80
Snap.....	60	Pulleys		Silicone Free	80
Spring Hooks	60, 61	Cast Iron.....	48	Sliding Compound.....	79, 80
J-Bolts	71	Hay.....	49	Spray	80
J-Lag Hooks.....	71	Nylon.....	47, 48	Snap Hooks.....	60
Kwik-Loc™.....	25	Plastic Pulleys.....	47	Split Rings	59
Klein® Chicago Cable Grips	39	Split Bracket	48	Spreader Bar.....	98
Klein® Haven Cable Grips	39	Stainless Steel.....	49	Springs	
Lap Links	58	Swivel Eye	48, 49	Accessories	106
Lighting Restraint Cables ..	18, 126	Quick Links.....	56	Bumper Spring.....	106
Links		Rollers		Extension Spring.....	104, 105
Alloy Grab	33	Nylon.....	82	Torsion Spring 100, 101, 102, 103	
Alloy Oval.....	33	Precision Bearing.....	83	Spring Fittings	107
Forged Carbon Pear	56	Sealed	83	Spring Assemblies.....	98, 99
Load Binders		Steel.....	83, 84	Spring Fittings	
Lever Type	32	Truck Door Rollers.....	123	Cones & Drums	107, 108
Ratchet Type.....	32	Railing Hardware.....	124, 125	Couplers & Collars.....	107
Loop Nuts	72	Rotation Resistant Wire Rope	14	Winding Sleeve	42, 100
Locks		S-Hooks	59	Spring Hooks	60, 61
Components	92, 93	Scrubs.....	78	Stainless Steel Products	
Handles & Cylinders	91	Shackles		Blocks	46

Cable 9, 10
 Chain 28
 Maze Nails 76
 Quick Links 56
 Shackles 68
 Sheaves 46
 Sleeves 21
 S-Hooks 59
 Spring Hooks 61
 Swivels 57
 Thimbles 22
 Turnbuckles 55
 Wire Rope 12
 Wire Rope Clips 16
 Staples 59
 Step Bolts 123
 Swage Fittings
 Aluminum 20, 21
 Copper 20, 21, 22
 Zinc Plated Copper 20
 Stainless Steel 21
 Swaging Tools 36, 37, 38
 Swivels 58
 Thimbles
 AN-Type 22
 Heavy Duty 22, 23
 Stainless Steel 22
 Standard Duty 22, 23
 Tools
 Angle Shears 42
 Applicator 41
 Cable Cutting 35, 36, 37
 Cable Meter 41
 Cable Grips 40
 Calipers (Electronic) 40
 Chain Cutting 35
 Coir Twine 41
 Extension Cords 41
 Hops Clips 41
 Klein® Chicago Cable Grips .. 39
 Klein® Haven Cable Grips 39
 Maasdam® Pow'r-Pulls 40
 Repair Blocks 42
 Ronan Cutters 41
 Spring Tools 42
 Swaging 36, 37
 Swaging Tool Kits 38
 Truck Door Hardware
 Assemblies 119, 120
 Brackets 120
 Drums 121
 Handles 120
 Hinges 120
 Rollers 121
 Step Bolts 121
 Turnbuckles
 Galvanized 52, 53, 54
 Stainless Steel 55
 Stub End 55
 Warnings and Cautions 130, 131
 Washers
 Eyebolt 71
 Flat 74
 Weatherseal
 Astragal 117
 Bottom Seal 113, 114, 115, 116, 117
 Mini Warehouse 113, 114
 Retainers 117
 Reverse Angle Seal 112
 Ridgid Door Stop 111
 Rodent Control 118
 Rolling Steel Seal 113
 Threshold 118
 Top Seal 113
 Spring Filler 118
 Stucco Jamb Seal 112
 Uniflex™ 109
 Wood Grain Jamb Seal 111
 Winches
 Ceiling 49
 Hand 50
 Worm Gear 49
 Wire Rope
 Assemblies 19, 126
 Fiber Core 12
 Galvanized 13, 14

Rotation Resistant 14
 Steel Center 12
 Stainless Steel T304 13
 Wire Rope Clips
 Double Saddle 16
 Drop Forged 15, 16
 Malleable 15
 Stainless Steel 16
 Yarding Blocks 48



ORDER ONLINE

Go to www.fehr.com and sign in with your B2B login for a one-stop solution to all your cable and hardware needs. Through our website you will be able to:

- See our complete line of chain, cable, wire rope and rigging hardware.
- Have access to our competitive distributor pricing.
- Quickly place and track your orders.
- Manage and edit your account.

PRICES: Prices are subject to change without notice. Invoices are based upon prices in effect at time of order. Check our website for up to date pricing. Fuel surcharges may apply.

TERMS OF PAYMENT: VISA, MasterCard, AMEX and Discover accepted. Net Cash 10 days for approved accounts.

MINIMUM INVOICE: \$50.00, FOB Saugerties, NY

LATE CHARGE: A late charge of 1.5% per month is added to accounts over sixty (60) days from date of invoice.

RETURNED CHECKS: A \$30.00 fee is charged for returned checks.

FREIGHT POLICY: All shipments are FOB warehouse. Freight Collect or Prepay and Add. Call 800.431.3095 to inquire about our Prepaid Freight Policy. Fehr Bros. Industries, Inc. reserves the right to ship by carrier of our choice. Policy subject to change.

COD fees, redelivery, inside delivery, lift gate, call for appointment, over length, residential delivery, airfreight charges and any other special handling or packaging charges are the responsibility of the customer.

Bills of lading must be signed with exception for missing goods or exposed damages. Freight claims for damaged

or missing materials are the responsibility of the buyer. All cartons must be inspected for concealed damage or shortage upon receipt. Claims must be submitted to the carrier within five (5) business days.

RETURNS: Fehr Bros. wants you to be 100% satisfied with our products and service. Merchandise in its original condition may be returned for credit within thirty (30) days of receipt of material. Our Customer Service Department will provide a Return Material Authorization (RMA) form and number on request. Affix the RMA number labels to the outer carton and return the form with the material, freight paid, to the warehouse indicated on the RMA instructions. Call 800.431.3095.

A restocking fee of 15% plus freight charges may apply. No freight collect or COD shipments will be accepted. Unauthorized shipments will be returned at the customer's expense. Special order material and material cut to custom specifications are not returnable.

WARRANTY: Fehr Bros. Industries, Inc. warrants its products against defective materials and workmanship at time of shipment. Damage in transit is the responsibility of the carrier. Claims are subject to inspection by our authorized representative, and liability is limited to replacement of material or refund of the purchase price. We cannot be responsible for labor charges and consequential damages.

Warnings and Cautions Governing the Sale and Use of Cable, Springs and Attachments

All products are sold subject to the following Warnings and Cautions and with the express understanding that the purchaser and/or user are thoroughly familiar with their proper use. Fehr Bros. Industries, Inc. assumes no responsibility for the use, misuse or misapplication of its products.

WORKING LOAD LIMIT: The Working Load Limit (WLL) is the maximum load which should be applied to the product under any condition. WLL is based on a load being uniformly applied in a straight-line pull. It is the responsibility of the end user to determine a WLL for each application. Many factors should be considered including, but not limited to, loads applied, speed of operation, acceleration, length of cable, shock loads, abrasion, corrosion, size, condition of drums and sheaves, and the danger to life and property should a cable break.

BREAKING STRENGTH: Breaking Strengths apply only to new, unused Cable. Do NOT use Breaking Strength for design or rating purposes. Use WLL instead.

AVOID SHOCK LOADS: Loads exceeding the static load caused by rapid change of movement. WLL will not apply.

MATCHING COMPONENTS: All attachments used with chain and wire rope must be of suitable material, type and strength to provide adequate safety protection. Attachments should have

WLL at least equal to the other components with which they are used.

INSPECTION: No product can operate indefinitely at its rated capacity. Cables must be lubricated and maintained in accordance with normal safety standards. Do not kink, knot or crush. Cable, wire rope, chain and attachments must be inspected regularly for any deterioration which may result in the loss of original strength. User must determine whether further use of product would constitute a safety hazard to life or property.

MARKING REQUIREMENTS: U.S. Customs Law requires that the end user of imported products be informed of the country of origin. All imported products sold by Fehr Bros. are marked accordingly. Resellers are responsible for relaying country of origin information to the end user.

SPECIFICATIONS: Product dimensions, weights, strengths and other specifications listed are approximate and may vary according to industry standards.

CHAIN AND ATTACHMENTS

WARNING: Use only Grade 80 Alloy Chain for overhead lifting purposes or where failure is likely to cause damage to property or persons. Proof Coil, High Test, and Grade 70 Transport Chains are not to be used for overhead lifting. Eliminate all twists and kinks in chain before using. All dimensions are nominal and all weights are approximate.

INSPECTION: All chain and attachments should be inspected regularly for visible damage, distortion, elongation, corrosion, wear, bent links, cracks, or nicks which can cause breakage or seriously reduce the strength and ability to perform safely.

MATCH COMPONENTS PROPERLY: Attachments should have WLL at least equal to the chain with which they are used.

AVOID SHOCK LOADS.

WINCHES

WARNING: Do not exceed the rated capacity of winches or other components. Winches are not to be used for lifting humans or loads overhead. Do not use winches to secure loads to a trailer; use appropriate tie-downs.

The rated winch capacity is based on one layer of line on the drum. As the line builds on the drum the capacity decreases.

Never fully extend the line under load. Keep out of the line of force of any load.

Maintain control of handle under load. Inspect and secure the handle regularly.

WIRE ROPE, CABLE AND ATTACHMENTS

WARNING: Cables are not suitable for use in aircraft controls.

BREAKING STRENGTHS: Breaking Strengths apply only to new, unused Wire Rope and Cable.

WORKING LOAD LIMIT: It is the responsibility of the ultimate user to determine a Working Load Limit for each application. Many factors should be considered included among, but not limited to: loads applied, speed of operation, acceleration or deceleration, length of rope or cable, shock loads, abrasion, corrosion, number, size, condition and location of drums and sheaves, facilities for inspection, and the danger to life and property should a rope or cable break.

Wire Ropes and Cables must be stored, used, lubricated and maintained in accordance with normal safety standards; and must be properly designed, maintained, and operated. Inspect regularly. Do not kink, knot or crush.

INSPECTION: No product can operate indefinitely at its rated capacity. Wire Rope and Cable must be inspected regularly for any deterioration which may result in the loss of original strength. User must determine whether further use of the rope would constitute a safety hazard to life or property.

Lubricate operating ropes regularly.

Keep out from under any raised loads and keep out of the line of force of any load.

AVOID SHOCK LOADS.



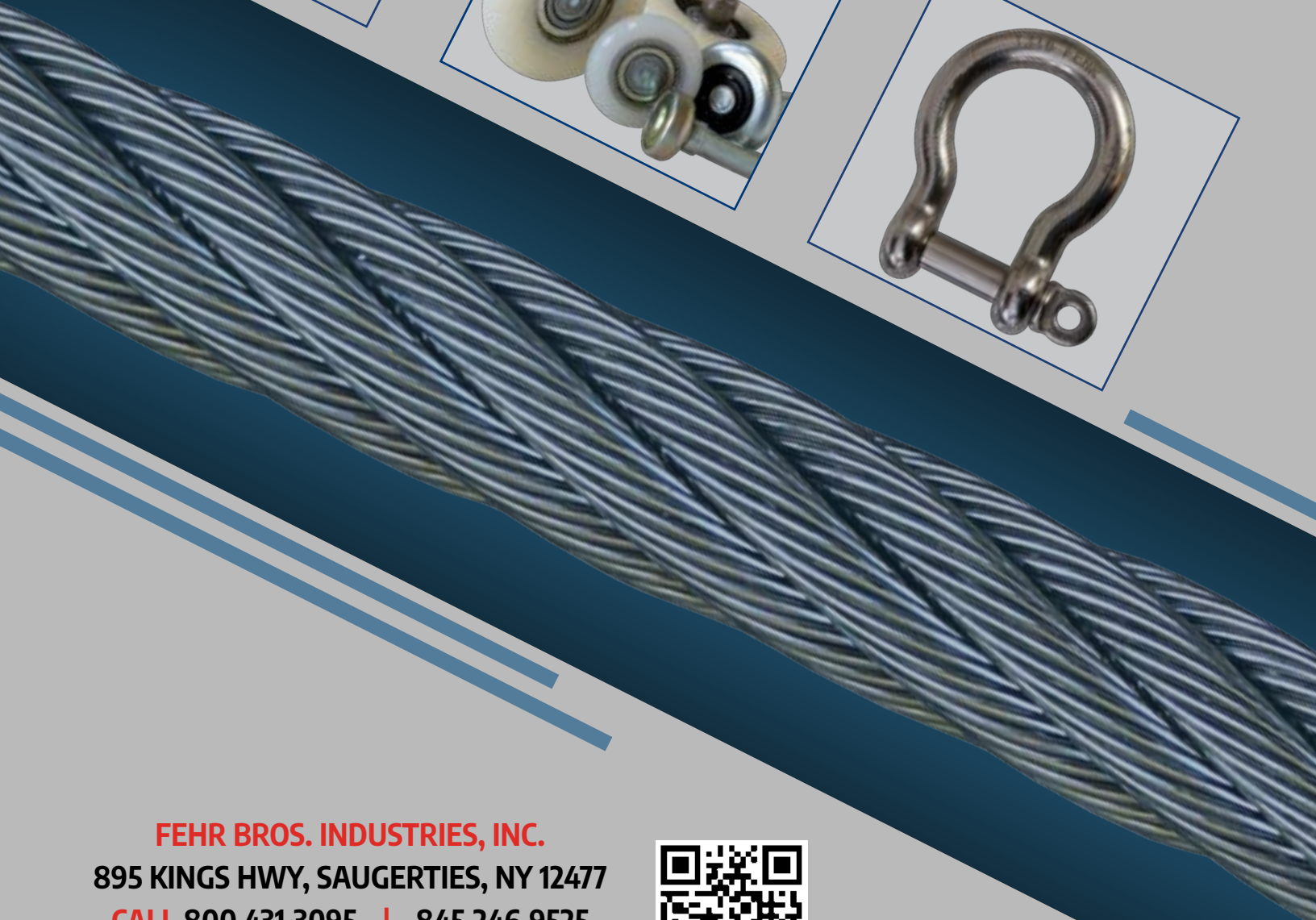
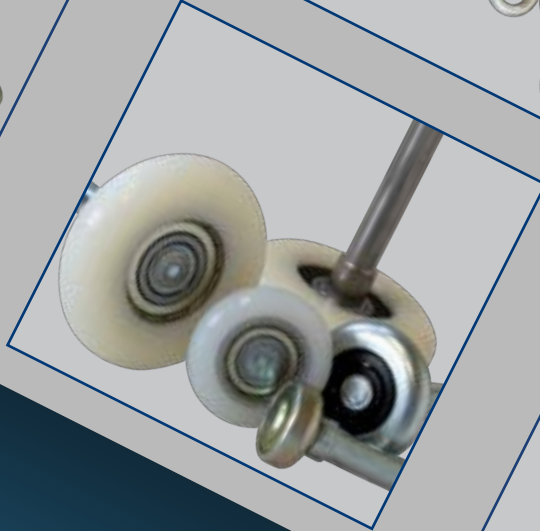

FEHR BROS. INDUSTRIES, INC.

895 KINGS HWY, SAUGERTIES, NY 12477

CALL 800.431.3095 | 845.246.9525

FAX 888.352.1790 | 845.246.3330

www.fehr.com

